

**PAKISTAN'S CHASHMA
NUCLEAR POWER PLANT
A preliminary study of some safety issues
and estimates of the consequences of
a severe accident**

Zia Mian*
A. H. Nayyar**

PU/CEES Report No. 321

December 1999

Center for Energy and Environmental Studies
Princeton Environmental Institute
Princeton University
Princeton, NJ 08544-5263
(609) 258-5445
www.princeton.edu/~cees

* Dr. Zia Mian is with the Center for Energy and Environmental Studies, Princeton University and also a Visiting Research Fellow, Sustainable Development Policy Institute, Islamabad.

** Dr. A. H. Nayyar is with the Department of Physics, Quaid-I-Azam University, Islamabad and also a Visiting Researcher of the Center for Energy and Environmental Studies, Princeton University.

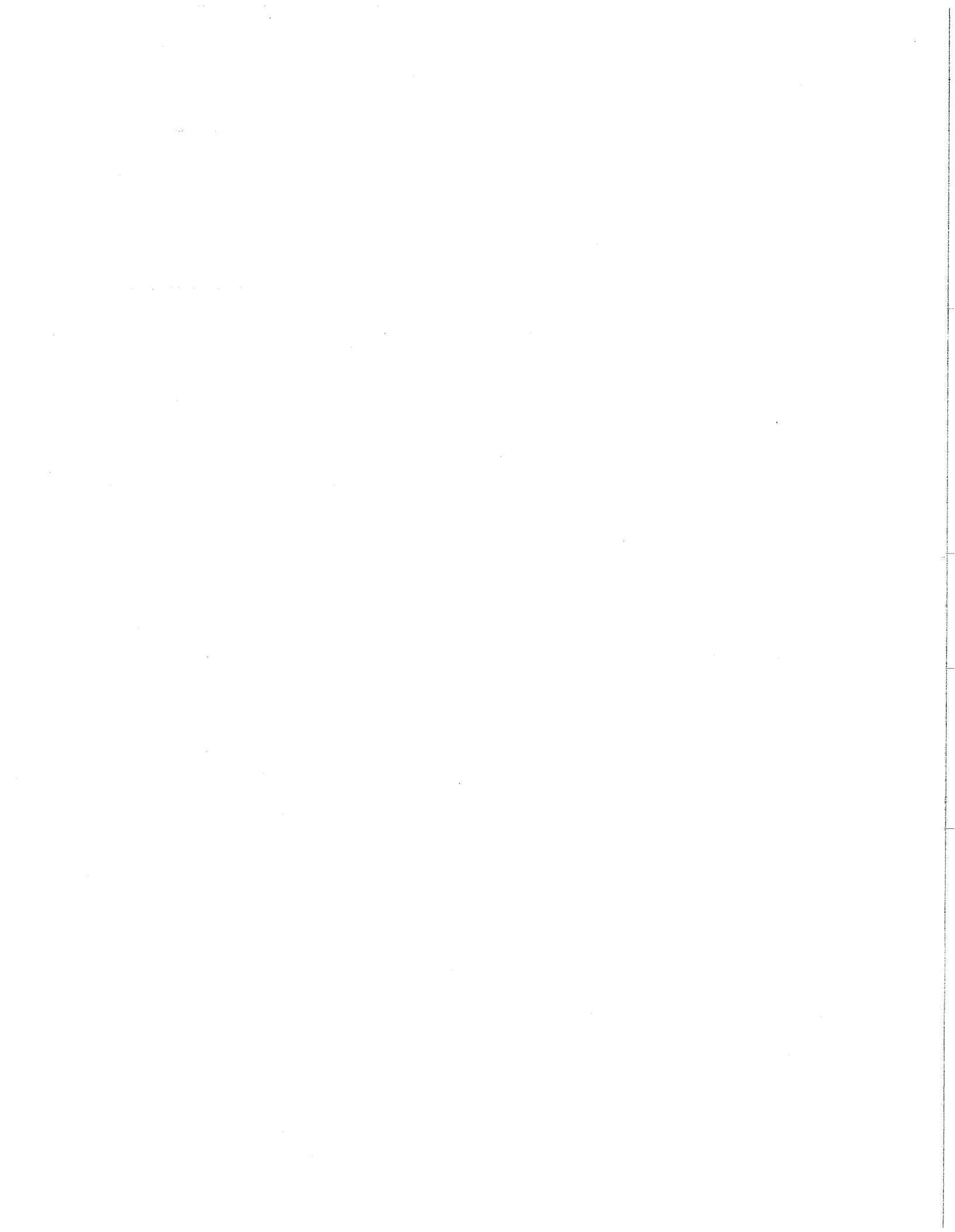

Contents

| | | |
|-------------------|--|-----------|
| | Abstract | 2 |
| I | The history of the Chashma nuclear power plant | 4 |
| II | The Chashma site | 8 |
| III | The Chashma nuclear power plant | 15 |
| IV | The accident at Qinshan | 20 |
| V | The experience of Kanupp | 23 |
| VI | Some concerns about an accident at Chashma | 27 |
| VII | Chashma core radionuclide inventory and possible release | 31 |
| VIII | The wedge model for atmospheric dispersion | 34 |
| IX | Population and population density | 38 |
| X | Radiation doses and health effects from an accident | 40 |
| XI | Thyroid doses and children | 43 |
| XII | Cancer incidence | 44 |
| XIII | Environmental effects | 47 |
| XIV | Effects on the irrigation and groundwater system | 49 |
| XV | Conclusion | 51 |
| Map 1 | Possible sites for nuclear power plants identified by PAEC | 54 |
| Map 2 | Map of Pakistan showing the Chashma site and major cities | 55 |
| Map 3 | The Chashma site and its surroundings | 56 |
| Map 4 | Epicenters of earthquakes 1905-1972 and related faults | 57 |
| Map 5 | Active faults and lineaments in Pakistan | 58 |
| Map 6 | Earthquake epicenters from the Tarbela Dam seismic network | 59 |
| Map 7 | Earthquake epicenters around Chashma | 60 |
| Map 8 | Areas affected by floods in Pakistan in 1992 | 61 |
| Appendix 1 | A comparison of Chashma and Qinshan-1 | 62 |
| Appendix 2 | Earthquakes with epicenters within 100 km of Chashma | 64 |
| Appendix 3 | Radioactive inventory and release from Chashma | 65 |
| Appendix 4 | Time integrated radioactivity at different distances from Chashma | 67 |
| Appendix 5 | Population and population density | 68 |
| Appendix 6 | Dose conversion factors | 69 |
| Appendix 7 | Radiation dose from an accident at Chashma | 70 |
| Appendix 8 | Thyroid doses | 71 |
| Appendix 9 | Radionuclide deposition on Chashma Barrage | 72 |

Abstract

The Chashma nuclear power plant in Pakistan is expected to begin producing power in March, 2000. Public information about the reactor is limited, but an analysis of available data suggests there may be grounds for concern about the safety of the reactor. Some of these concerns are outlined here and the effects of a severe reactor accident estimated.

The first concern about Chashma is the location of the reactor. The reactor is sited in an area that studies have shown to be seismically active and possibly able to generate a magnitude 7.0 - 7.5 earthquake. The reactor's site on the banks of the Indus River may increase the risk of an accident in response to an earthquake because the water-rich sandy soil there may be susceptible to liquefaction; a process in which the ground behaves as if it were liquid.

The second concern is the safety of the reactor design. Originally designed by the China National Nuclear Corporation as a replica of China's first indigenous reactor, Qinshan-1, the history of Chashma suggests that the design has been subject to repeated changes. Not all the suggestions made for improving the safety of the reactor appear to have been incorporated. The limited Chinese experience in reactor design and the changes that have been made may combine to make the behavior of the system as a whole less predictable and less reliable, and so less safe. The July 1998 accident at Qinshan-1 and China's subsequent resort to Western help to assess and repair the problem have exposed some aspects of the poor initial design. These limitations may apply to Chashma, but Pakistan would not have access to Western help to deal with them.

The reactor components are a third cause of concern. Unlike the prototype Qinshan-1 reactor, restrictions on the supply of nuclear technology to Pakistan have meant that Chashma's reactor pressure vessel, coolant pumps and control system, among other key systems, have been built in China. This is the first time these particular components and systems have been made in China and the lack of experience with setting the requirements for such components and quality control during manufacturing may increase the risk of structural failures and equipment malfunction. This risk is compounded by the institutional experience of the Pakistan Atomic Energy Commission which has been limited to one power reactor that is among the worst performing power reactors in the world.

The methodology outlined in the 1975 American Physical Society "Study On Light Water Reactor Safety" is used to consider the consequences of a severe accident at Chashma. Assumptions about the release of radionuclides from the reactor's core to the atmosphere are combined with a simple model for the atmospheric transport and deposition of a radioactive aerosol to derive estimates of the radiation dose to people at distances of up to 300 km from the reactor.

The radiation doses resulting from inhalation of the aerosol, the cloudshine from the passing cloud, and from contamination of the soil are estimated as causing, given the present population density, 12,000 - 23,000 cancer deaths, and perhaps three times as many cancer cases. The model suggests over 8,000 child deaths from thyroid cancer. Poverty, poor health care and other factors associated with underdevelopment would tend to increase this estimate.

It is estimated that radioactive contamination of the ground would make it necessary to evacuate the population out to a distance of about 70 km from the reactor for a limited period, and perhaps permanently displace people living within about 30 km. Agricultural activity in these and perhaps larger areas would be affected.

Radioactive contamination of the Indus river could be caused by deposition of the released aerosol and by groundwater leaching radionuclides from the core mass remaining after meltdown. These slow processes acting over decades could be speeded up by the presence of earthquake faults close to the site, which may create channels for the contaminated water to reach deep into the groundwater as well as migrate horizontally up to 100 km.

The issues raised by Chashma are sufficiently important and the implications of a severe accident so grave that the reactor should not be allowed to begin operation until these issues have been effectively addressed. At a minimum, operation of the reactor should not be allowed to begin until there has been a full, open, and independent expert review of the entire project, its possible public health and environmental impacts and a study of all the alternatives that could meet the energy production goal of Chashma.

I: The history of the Chashma nuclear power plant

It took Pakistan little more than decade to go from launching a limited program for research and development in atomic energy in 1954 to signing the deal for its first nuclear plant. In May 1965, the Pakistan Atomic Energy Commission (PAEC) asked Canadian General Electric to design and build a 137 MWe¹ reactor, to be located in Karachi (the Karachi Nuclear Power Plant, or KANUPP). It was commissioned in 1971.

The following year work began on an ambitious nuclear power plan as part of a larger International Atomic Energy Agency (IAEA) assessment of the potential role of nuclear power in meeting the energy demands of developing countries. This led the IAEA and PAEC to produce the 1975 Nuclear Power Planning Study for Pakistan. The plan proposed building eight 600 MWe nuclear power plants between 1982-1990, and nine 600 MWe units plus seven 800 MWe units between 1991-2000, with Pakistan having nuclear power amount to 60% of its projected installed capacity by 2000.² Chashma was identified as a site for some of these nuclear power plants.

Nuclear plans of another kind were being made at the same time. On 20 January 1972, barely six months after KANUPP achieved criticality, and a month after coming to power, President Zulfikar Ali Bhutto, a long standing and very public proponent of nuclear weapons for Pakistan, called together many of the country's leading scientists and asked about the feasibility of building nuclear weapons.³ To carry this plan forward, Munir Ahmad Khan, a US trained reactor engineer who had worked at the IAEA, was appointed the new chairman of PAEC.

In the wake of the decision to build nuclear weapons Pakistan sought to purchase a reprocessing plant from France.⁴ With no civilian use for the plutonium that would be produced by reprocessing Kanupp spent fuel, it was evident that Pakistan was setting out on the road to nuclear weapons.⁵

However, these developments in Pakistan elicited little response from the international community until India's nuclear weapons test of May 1974. The test led to international efforts to restrict the further development of nuclear weapons in the region, including denying nuclear technology to Pakistan and India. The more significant impacts were felt in Pakistan. In December 1976 Canada withdrew support for the Kanupp reactor and terminated the sale of a nuclear fuel fabrication plant, citing Pakistan's refusal to either sign the Nuclear Nonproliferation Treaty or otherwise accept fullscope safeguards on its nuclear complex.⁶ Under US pressure, France refused to supply a reprocessing plant to Pakistan, and the United States imposed sanctions against Pakistan in 1978, suspending all economic and military aid. These restrictions were further tightened in 1979 to ban all but humanitarian assistance, in the hope of curtailing Pakistan's nuclear weapons program.

¹ MWe, one million watts of electricity, a typical unit of electric power. Typically, this is one third of the thermal output (MWth) of a nuclear power plant.

² International Atomic Energy Agency, *Nuclear Power Planning Study for Pakistan*, IAEA, Vienna, 1975, p. 6.

³ *Pride, honour at all costs to be redeemed - scientists role vital, says Bhutto*, Dawn, 21 January 1972.

⁴ See for instance Ashok Kapur, *Pakistan's nuclear development*, Croom Helm, London, 1987, pp. 155-160.

⁵ Plutonium is one of two fissile materials, the other being highly enriched uranium, that can be used to build nuclear weapons.

⁶ Duane Bratt, *CANDU or CANDON'T: Competing values behind Canada's nuclear sales*, The Nonproliferation Review, Spring-Summer, 1998, pp.1-16.

Left largely to fend for itself, except for support from China, and facing financial difficulties because of a growing trade deficit and debt burden, during the late 1970s Pakistan managed to develop a capacity to mine and mill uranium, produce fuel for Kanupp, and to keep the reactor running.⁷ The nuclear weapons program also developed over this time, with Pakistan moving away from trying to acquire a reprocessing capability and turning instead to developing uranium enrichment; production of weapons grade uranium through the use of gas centrifuges began around 1981 or 1982.⁸

Pakistan's period of relative isolation began to end with the December 1979 Soviet invasion of Afghanistan. Following the 1981 election of Ronald Reagan as US president, there was a dramatic increase in US aid and support to Pakistan. This support, amounting to several billion dollars of military and economic aid, came despite Pakistan's nuclear weapons program.

In this new environment, an emboldened PAEC resumed its search for nuclear power plants. In 1982, after a study by the Spanish engineering and consulting company Sener, Pakistan approved a \$1.5 billion plan for a 937 MWe nuclear power plant to be located at Chashma, to be completed by 1988.⁹ It was to be the first of a proposed six 1000 MWe reactors at the site.¹⁰

Several major nuclear engineering companies initially expressed interest in bidding for the planned reactor, including Westinghouse, General Electric, Framatome, Kraftwerk Union, and Hitachi.¹¹ This interest did not mature, despite the prospect of future orders for more reactors. The deadlines for the bids had to be postponed five times.¹² When after 16 months there had been no bids, the deadline for bids was postponed indefinitely.¹³

Pakistan's effort to acquire the reactor was raised at the highest levels; President Zia-ul-Haq met with Chancellor Kohl of Germany¹⁴ and had discussions with France.¹⁵ Despite Pakistan's major role in supporting the United States against the Soviet Union in Afghanistan even the Soviet Union was asked to supply reactors.¹⁶ But to no avail. The Western reluctance to supply a nuclear power reactor to Pakistan, despite the financial incentives, was attributed to US pressure on suppliers and concerns about Pakistan's nuclear weapons program, as well as on Pakistan's unwillingness to accept full-scope safeguards.¹⁷

⁷ Pakistan Atomic Energy Commission, *Kanupp, 25 years of safe operation*, Pakistan Atomic Energy Commission, Islamabad, 1996.

⁸ A.Q. Khan, *Dr A.Q. Khan Research Laboratories, Kahuta: Twenty years of excellence and service*, The Friday Times, 5-11 September 1996.

⁹ *Approval for a 937 MWe nuclear unit at Chashma*, Nucleonics Week, vol. 23, no. 15, p. 2, 15 April, 1982.

¹⁰ Shahid-ur-Rehman Khan, *Pakistan issues plant tender*, Nucleonics Week, vol. 23, no. 49, p.3, 9 December, 1982.

¹¹ Ann MacLachlan, *The final stages of work on evaluation procedures for bids*, Nucleonics Week, vol. 24, no. 10, p. 11, 10 March, 1983.

¹² *The Pakistan Atomic Energy Commission has again postponed the deadline for bids*, Nucleonics Week, vol. 25, no. 1, p. 10, 5 January, 1984.

¹³ *Pakistan has indefinitely postponed*, Nucleonics Week, vol. 25, no. 14, p. 6, 5 April, 1984.

¹⁴ Shahid-ur-Rehman, *The Chashma reactor was discussed by the German and Pakistani heads of state*, Nucleonics Week, vol. 25, no. 42, p. 10, 18 October, 1984.

¹⁵ Shahid-ur-Rehman, *Pakistan holds reactor talks with France*, Nucleonics Week, vol. 27, no. 50, p. 2, 11 December, 1986.

¹⁶ Shahid-ur-Rehman Khan, *Soviets say they will not supply Pakistan with nuclear reactor*, Nucleonics Week, vol. 25, no. 47, p. 11, 22 November, 1984.

¹⁷ Rob Laufer, *While hesitant to discuss U.S. policy*, Nucleonics Week, vol. 23, no. 37, p. 4, 16 September, 1982.

In 1985, Pakistan began work on a small nuclear reactor at Khushab, in central Punjab.¹⁸ It is a natural uranium fuelled, heavy water moderated design similar to the Karachi nuclear power plant, and the earlier Canadian NRX reactor -- which formed the basis for the CIRUS reactor sold to India and was used to produce plutonium for India's 1974 nuclear weapon test.¹⁹ Outside the International Atomic Agency's safeguards system (which monitors nuclear facilities to ensure they are not used to make nuclear weapons material), this 50 MWth reactor was clearly meant for producing plutonium for Pakistan's nuclear weapons, perhaps with China's assistance.²⁰ The reactor was reportedly completed in 1996.²¹ But, it may only have started operating in 1998.²²

It was against this background that in the late 1980s Pakistan turned to China for a larger nuclear power plant to be built at Chashma. The agreement between Pakistan and the China National Nuclear Corporation (CNNC) for the supply of the Chashma reactor was reached in late 1989, with the final contract signed in Beijing on 31 December 1991.²³ In March 1992 China acceded to the NPT and the Safeguards Agreement for Chashma between Pakistan, China and the IAEA was approved on 19 June 1992, and signed on 24 February 1993.²⁴ Unlike Western suppliers, China did not insist on fullscope safeguards -- which would have covered all of Pakistan's nuclear complex, including its nuclear weapons facilities.

China's limited experience with designing and building nuclear power stations meant that the Chashma project had to be scaled down significantly from the original plan. Instead of the envisaged 900-1000 MWe power plant, the Chashma nuclear power plant is a 300 MWe (998.6 Megawatts thermal) pressurized water reactor.²⁵ It is based closely on the design of China's Qinshan-1 reactor, which is located on the eastern coast of China 126 km south of Shanghai. [see Appendix 1 for a comparison of the characteristics of Qinshan-1 and Chashma]

It was originally anticipated that work on Chashma would begin in December 1990 and be completed by mid-1996.²⁶ By 1992 it was claimed that the reactor would be operating by 1998.²⁷ The first concrete was poured at Chashma in August 1993.²⁸ The dome of the cylindrical reactor

¹⁸ The Nation, 13 April 1998, <http://www.nation.com.pk/lead.htm>

¹⁹ Shahid-ur-Rehman Khan, *Pakistan media says Khushab chief retired over possible CTBT signing*, Nucleonics Week, 26 November, 1998.

²⁰ Mark Hibbs, *Bhutto may finish plutonium reactor without agreement on fissile stocks*, Nucleonics Week, vol. 35, no. 40, p. 10, 6 October, 1994.

²¹ Ashraf Mumtaz, *Indigenous reactor ready*, Dawn, 7 March, 1996.

²² Mark Hibbs, *U.S. now believes Pakistan to use Khushab plutonium in bomb*, Nucleonics Week, 17 July, 1998.

²³ Pakistan Atomic Energy Commission, *Annual report, 1991-1992*, Pakistan Atomic Energy Commission, Islamabad.

²⁴ International Atomic Energy Agency, Information Circular, *Agreement of 24 February 1993 between the International Atomic Energy Agency and the government of the Islamic Republic of Pakistan for the application of safeguards in connection with the supply of a nuclear power station from the People's Republic of China*, INFCIRC 418, IAEA, Vienna, March 1993, <http://www.iaea.or.at/worldatom/infcircs/inf418.html>.

²⁵ Pakistan Atomic Energy Commission, *Chashma nuclear power plant*, Pakistan Atomic Energy Commission, Islamabad, undated.

²⁶ Shahid-ur-Rehman Khan, *China agrees to supply 300 MW PWR to Pakistan*, Nucleonics Week, vol. 30, no. 47, p. 1, 23 November, 1989.

²⁷ Altaf Yawar, *Chinese aided nuclear power plant discussed*, The Pakistan Times, 25 October 1992, p. 14, JPRS-TND-92-040, 30 October 1992.

²⁸ Abdul Rauf Siddiqi, *Chashma building on schedule, Kanupp life extension planned*, Nucleonics Week, vol. 37, no. 49, p. 16, 5 December, 1996.

containment building was put in place in on 20 November 1995.²⁹ In November 1995, the General manager of Chashma claimed the timing for the next major milestones for Chashma were:³⁰

Fuel Loading Permit: 1 May 1998

Fuel Loading: 25 May 1998

Connection to Grid: 25 October 1998

Commercial Operation: 25 March 1999

These dates too have slipped. It has been suggested that this may have partly been due to financial reasons. In 1995, the World Bank and the Japanese Overseas Economic Cooperation Fund (Japan is the largest aid donor to Pakistan) recommended that Pakistan drop the Chashma plant since it was not cost effective.³¹ In late 1996, a caretaker administration that took office for three months after the dismissal of the Benazir Bhutto government slashed the funding to Chashma by over 60%, but this was subsequently restored by the Nawaz Sharif government that came to power in 1997.³²

The PAEC has never officially given the cost of the Chashma plant, or the financial terms negotiated with China. The contract for Chashma requires that China supply not just the nuclear power plant but also the fuel for the initial core and five reloads, associated core components and services, and transfer the technology to design and fabricate the fuel.³³ Estimates for the cost have varied widely. At the time construction was about to begin, nuclear industry sources reported that Chashma was estimated to cost about \$600 million.³⁴ In 1995, it was claimed the actual cost of Chashma had increased to \$1.033 billion.³⁵ However, with the project close to completion, it is reported that Chashma was estimated to have cost Rs 31.02 billion, excluding foreign aid; at the current exchange rate this is just over \$600 million.³⁶

In July 1999, three years after work on Chashma was originally supposed to have been completed, PAEC announced that Chashma was expected to begin commercial operation by the end of October 1999.³⁷ This target date has also been missed. It was only on 23 November, that loading started of the reactor's 36 tons of fuel.³⁸ For the Qinshan-1 prototype, fuel loading took about nine days followed by three months of preparation and testing before the reactor core went critical (i.e. sustained a nuclear chain reaction) and another nine months before the nuclear power plant reached full power for the first time.³⁹ This would suggest Chashma may not be ready for full power operation until the end of 2000. PAEC seems to be preparing to cut short this schedule.

²⁹ Mirza Azfar Beg and Saeed A. Siddiqi, *Chashma Nuclear power project*, Dawn, 21 November 1995.

³⁰ Mirza Azfar Beg and Saeed A. Siddiqi, *Chashma Nuclear power project*, Dawn, 21 November 1995.

³¹ Shahid-ur-Rehman Khan, *Finance Review urges Pakistan to drop to drop costly Chashma Project*, Nucleonics Week, 3 August, 1995.

³² Abdul Rauf Siddiqui, *New Pakistani government restores full funding for Chashma*, Nucleonics Week, 27 March, 1997.

³³ Pakistan Atomic Energy Commission, *Annual report, 1992-1993*, Pakistan Atomic Energy Commission, Islamabad.

³⁴ *Pakistan/China*, Nucleonics Week, 9 January, 1992.

³⁵ Shahid-ur-Rehman Khan, *PAEC head denies report that US, money ills derail Chashma -2*, Nucleonics Week, 6 July, 1995.

³⁶ Abdul Rauf Siddiqi, *Pakistan allocates funds for Chashma completion*, Nucleonics Week, 1 July 1999.

³⁷ *Country's second nuclear power plant to start in October*, The News, 12 July, 1999.

³⁸ *Chashma power plant goes nuclear*, Dawn, 24 November, 1999.

³⁹ Ouyang Yu, *Preparing Qinshan for full power*, Nuclear Engineering International, vol. 38, No. 465, 1993, p. 30.

in the case of Chashma; the reactor is now scheduled to commence operation at the end of March 2000.⁴⁰

There are reports that Pakistan may be seeking a deal for the supply of a second nuclear power plant of the same design to be sited at Chashma.⁴¹ PAEC also has larger ambitions. It has claimed that since Pakistan is now self-reliant in enriched uranium, zirconium and other nuclear reactor components, in addition to a second unit at Chashma, more nuclear power plants should be build.⁴²

II: The Chashma site

The Chashma nuclear power plant is located on the left bank of Pakistan's major river, the Indus, 32 km south of Mianwali city.⁴³ It was one of the 12 possible sites identified in the 1975 PAEC Nuclear Power Planning Study for the 24 reactors the study proposed should be built in Pakistan over a period of 18 years [see Map 1]. These sites were characterized as desirable on the basis of there being access to water for cooling, ease of transport of construction materials and components, proximity to transmission lines and areas with potentially high demand for electricity, and appropriate geological conditions and levels of earthquake activity.

Chashma fits some of these criteria. It is close to a railway line and roads. It is within 200 km of several major cities; Peshawar to the north, Islamabad and Rawalpindi to the north-east, Lahore to the east and Multan to the south [see Map 2]. However, there is evidence that the geological and seismic characteristics of the Chashma site may create risks for a nuclear power plant.

In mapping possible sites for nuclear power plants, PAEC's 1975 study recognized that Pakistan lay in a part of the world which is "known for its seismic instability" and that the country had "several seismic zones".⁴⁴ It observed that "No nuclear power plants in the very active regions are being considered", but admitted that "many possible sites... are in the lower active seismic region... In this region one still finds many earthquake epicenters, so that it is important to provide solid foundations and/or severe seismic design for nuclear power plants".⁴⁵

The Chashma site was one of those that caused concern. Among the early critics was I. H. Usmani, a scientist and civil servant who had served as Chairman of the Pakistan Atomic Energy Commission from 1960-1972, before being replaced by Munir Ahmad Khan. Usmani was reported to be "concerned not only about the seismic integrity of the site, but also about the fact

⁴⁰ *Pakistan to build more N-power plants: Ishfaq*, The News, 24 November, 1999.

⁴¹ Shahid-ur-Rehman Khan, *China may build another PWR at Pakistan's Chashma station*, Nucleonics Week, vol. 39, no. 9, p. 1, February 26, 1998 and *Chashma N-power plant completed*, The News, 10 December, 1998.

⁴² Rauf Siddiqi, *Pakistan ready to supply larger domestic nuclear power industry*, Nucleonics Week, vol. 40, no. 7, p. 15, 18 February, 1999.

⁴³ *Chashma Nuclear power Plant*, PAEC, undated.

⁴⁴ International Atomic Energy Agency, *Nuclear Power Planning Study for Pakistan*, IAEA, Vienna, 1975, p. 24.

⁴⁵ International Atomic Energy Agency, *Nuclear Power Planning Study for Pakistan*, IAEA, Vienna, 1975, p. 24. An earthquake epicenter is the point on the surface of the Earth directly above the source of the earthquake.

that it sits on the banks of the Indus River."⁴⁶ [see Map 3] His criticisms in the early 1980s provoked Pakistan's President, General Zia-ul-Haq, to send "a written request not to continue public discussion of such topics."⁴⁷ This has remained the official attitude towards the safety of Pakistan's nuclear facilities.

There is no doubt that Pakistan is very seismically active, since it stretches south from the continental collision zone between India and Asia marked by the Himalayas and is bounded on the west by the major earthquake faults and mountains that separate it from Iran and Afghanistan.⁴⁸ Map 4 shows the scattered epicenters of earthquakes in Pakistan between 1905-1972 and Map 5 shows the dense pattern of geological faults inferred from these earthquakes and from aerial photographs and Landsat satellite images.

These maps, while useful, may significantly under-represent the seismicity and seismic hazards in Pakistan.⁴⁹ Most of the earthquake data in these maps predates the development of seismology and seismological data collection in Pakistan and depends on observations made from far away, from historical records or from interpreting large scale features in the surface geology. Large earthquakes at a particular site may have recurrence times much greater than the period covered by available seismic records. Aerial and satellite imagery can complement the seismic record by identifying faults where earthquakes may take place but can not necessarily locate faults which may be buried.

The US Nuclear Regulatory Commission (NRC) guidelines require that the comprehensive geological, seismological, geophysical, and geotechnical investigations of the proposed site for a nuclear plant should extend out to a distance of 320 km (200 miles) of the site, especially to identify possible earthquake sources.⁵⁰ These investigations should include looking at the pattern of earthquake activity in the area for the past 2 million years. More detailed studies are required of the area within 40 km of the site, and even greater scrutiny of the area within 8 km of the site.

PAEC has not released the results of the geological and geophysical surveys it conducted for determining the suitability of the Chashma site. In the absence of this data, it is possible to gain only limited insight into the possible risks.

One indication of the suitability of the site can be had from international seismological observations. The US Geological Survey's National Earthquake Information Center database lists the time, magnitude, depth and epicenter of earthquakes recorded around the world over the past few decades. It shows a total of 271 earthquakes as having been detected and catalogued between 1973 and 1999 with epicenters within about 320 km of the Chashma site.⁵¹ Among these, 24

⁴⁶ Rob Laufer, *Pakistan's nuclear patriarch faults homelands nuclear policies*, Nucleonics Week, vol. 22, no. 1, p. 4, 8 January, 1981.

⁴⁷ Rob Laufer, *Pakistan's nuclear patriarch faults homelands nuclear policies*, Nucleonics Week, vol. 22, no. 1, p. 4, 8 January, 1981.

⁴⁸ See for instance L. Seeber and K. Jacob, *Earthquake prediction in Pakistan*, United States Geological Survey Open File Report No. 80-1157, 1980.

⁴⁹ R.C. Quittmeyer, A. Farah, and K.H. Jacob, *The seismicity of Pakistan and its relation to surface faults*, in *Geodynamics of Pakistan*, eds. A. Farah and K.A DeJong, Geological Survey of Pakistan, Quetta, 1979, pp. 271-284.

⁵⁰ US Nuclear Regulatory Commission, *Identification and Characterization of Seismic Sources and Determination of Safe Shutdown Earthquake Ground Motion*, Regulatory Guide 1.165, March 1997, <http://www.nrc.gov/NRC/RG/01/01-165.html>.

⁵¹ The NEIC website is at <http://earthquake.usgs.gov> and it is assumed that Chashma is located at 32.27N 71.20E.

earthquakes were within 100 km or so of the site [listed in Appendix 2], of which five earthquakes were within 40 km.

Some information, albeit old, on the pattern of earthquake activity and the location and size of earthquake faults in the vicinity of Chashma is available. It comes from a series of studies in the mid-1970s conducted for PAEC by the Lamont-Doherty Geological Observatory of Columbia University (in New York) specifically to investigate the seismic hazards at the site.⁵² These studies used field observations and data from two seismometer networks -- the first was installed in 1973 to assess the hazards to the proposed site for Tarbela Dam a few hundred km from Chashma, and the second emplaced around Chashma in 1975.

The third and final Lamont-Doherty report, from April 1977, offers the most detailed data on the seismicity and earthquake faults close to the site. Maps 6 and 7 show respectively the earthquakes detected by the Tarbela Dam network of seismic stations between June 1974 and July 1975, and those based on six months of data collected in 1976 from both the networks. From Map 6, it can be seen that the Chashma site is located close to a line of earthquakes, suggesting a fault or series of faults. Map 7 shows some inferred faults and the 19 earthquake epicenters located within about 50 km of the Chashma site that were observed during this six month period. The nearest earthquake recorded to the site had an epicentral distance of less than 5 km.⁵³

By 1979, after three years of operation, the seismometers had detected 10,000 earthquakes within a 400 by 500 km area.⁵⁴ From the seismic data, the Lamont-Doherty study inferred that "the total length of active fault segments within 100 km of Chashma is probably larger than 220 km".⁵⁵ Of particular concern may be a set of parallel, seismically active faults near the Chashma site, one of which the study noted may be "located very near the site, possibly directly below".⁵⁶ This fault may be as much as 100 km long and 35 km deep, making it capable of generating a possible magnitude 7.0-7.5 earthquake, if the whole fault were to slip.⁵⁷ The study concluded that "the seismic risk at the Chashma site is quite severe".⁵⁸

The PAEC seems to have ignored the Lamont-Doherty report. One reason may have been simply its timing, and its source. In 1977 Pakistan's nuclear program was under pressure from the United States, which was intent on trying to restrict the development of Pakistan's nuclear weapons capability. The report, which leaves little doubt that its authors consider Chashma to be an unsuitable site for a nuclear power plant, may have been seen as another part of these US efforts.

⁵² L. Seeber, J. Armbruster, K.H. Jacob, *Seismotectonic study in the vicinity of the Chashma nuclear power plant site, Pakistan*, report no. 3, April 1977.

⁵³ L. Seeber, J. Armbruster, K.H. Jacob, *Seismotectonic study in the vicinity of the Chashma nuclear power plant site, Pakistan*, report no. 3, April 1977, p. 11.

⁵⁴ L. Seeber, J. Armbruster, *Seismicity of the Hazara Arc in Northern Pakistan: Decollement vs. Basement Faulting*, in *Geodynamics of Pakistan*, eds. A. Farah and K. A. DeJong, Geological Survey of Pakistan, Quetta, 1979, pp. 129-142.

⁵⁵ L. Seeber, J. Armbruster, K.H. Jacob, *Seismotectonic study in the vicinity of the Chashma nuclear power plant site, Pakistan*, report no. 3, April 1977, p. 30.

⁵⁶ L. Seeber, J. Armbruster, K.H. Jacob, *Seismotectonic study in the vicinity of the Chashma nuclear power plant site, Pakistan*, report no. 3, April 1977, p. 34, p. 25.

⁵⁷ L. Seeber, J. Armbruster, K.H. Jacob, *Seismotectonic study in the vicinity of the Chashma nuclear power plant site, Pakistan*, report no. 3, April 1977, p. 32.

⁵⁸ L. Seeber, J. Armbruster, K. H. Jacob, *Seismotectonic study in the vicinity of the Chashma nuclear power plant site, Pakistan*, report no. 3, April 1977, p. 34.

It is possible PAEC's subsequent research at Chashma has made the Lamont-Doherty report's conclusions invalid and there may be no significant danger of a large earthquake at the site. But PAEC has not made public any such analysis. Instead, it reports only that a Site Evaluation Report for Chashma was prepared in 1984 and subsequently revised for a 300 MW plant.⁵⁹ This revision may have been insufficient, since PAEC subsequently asked for a further seismic re-evaluation of the site in 1986-1987 from the Italian engineering company ISMES.⁶⁰ While the report is confidential, ISMES officials concede that in assessing earthquake risks "When few earthquakes have been recorded... and maybe they have been poorly located (because they have been recorded by few or very remote instruments) the achievement of realistic estimates may be difficult".⁶¹

This caution seems to have been warranted. PAEC has referred to an IAEA Site Review Mission in November 1990 which reviewed all the previous site studies and investigations, and recommended "updating of Chashma site studies and additional site investigations".⁶² These were reported to have been completed in 1993-1994.⁶³ This is after work had started at the site. Reports at the time suggested that "geological experts and some Pakistani officials charge that the reactor site was chosen for political reasons and that earthquake dangers discovered earlier were hushed up."⁶⁴

There is no information on what siting guidelines PAEC has used for Chashma. The US NRC guidelines for siting nuclear power plants are that sites should be "those with a minimal likelihood of surface or near-surface deformation and a minimal likelihood of earthquakes on faults in the site vicinity (within a radius of 8 km)."⁶⁵ If applied, these guidelines would have ruled out the current location of the Chashma reactor, since it has had earthquakes recorded within 5 km of the site and may have a fault directly beneath it.

There are other NRC guidelines that Chashma appears not meet. To reduce the effects of an earthquake on a reactor NRC regulations suggest that "Sites with competent bedrock generally have suitable foundation conditions."⁶⁶ In other words, the reactor should be built on or anchored to hard rock that would serve to reduce the shaking it would feel from an earthquake. A similar criterion is used in Japan, which has considerable seismic activity and has built a number of nuclear power plants -- the earthquakes in Japan, while large are usually very deep and far out at sea.

At Chashma, it seems bedrock was inaccessible at the site. According to a description by Chashma's General Manager, "The plant is constructed on a concrete mat in alluvial sand".⁶⁷

⁵⁹ Pakistan Atomic Energy Commission, *Annual report, 1991-1992*, Pakistan Atomic Energy Commission, Islamabad.

⁶⁰ Pakistan Atomic Energy Commission, *Annual report, 1986-1987*, Pakistan Atomic Energy Commission, Islamabad.

⁶¹ ISMES, personal communication, September 1998.

⁶² Pakistan Atomic Energy Commission, *Chashma nuclear power project: assurance of safety and quality*, PakAtom- Newsletter of the Pakistan Atomic Energy Commission, May-June 1995, p. 5.

⁶³ Pakistan Atomic Energy Commission, *Annual report 1993-1994*, Pakistan Atomic Energy Commission, Islamabad.

⁶⁴ Abdus Sattar Ghazali, *Who should determine Pakistan's nuclear policy?*, Dawn, 19th September 1993.

⁶⁵ US Nuclear Regulatory Commission, *General site suitability criteria for nuclear power stations*, Regulatory Guide 4.7, April 1998, http://www.nrc.gov/NRC/RG/04/04-007r2.html#_1_19.

⁶⁶ US Nuclear Regulatory Commission, *General site suitability criteria for nuclear power stations*, Regulatory Guide 4.7, http://www.nrc.gov/NRC/RG/04/04-007r2.html#_1_18.

⁶⁷ Mirza Azfar Beg, S.A. Siddiqi, *Chashma nuclear power project*, Dawn, 21 November, 1995.

Another senior Chashma engineer has referred to a reactor sited on 150-400 m thick soft soil that has been deposited by a river.⁶⁸

The possible effects of an earthquake at any site are a result of the ground acceleration induced there. This is determined by the earthquake's magnitude, its distance from the site, and the absorption of the seismic energy by the intervening material, as well as any site specific effects.

To estimate the ground acceleration requires a relationship for the variation of seismic energy with distance. A 1994 seismic risk analysis for Pakistan reports that there is no attenuation equation available for Pakistan (a good indication that the seismological characteristics are poorly understood), and after comparing existing attenuation relations adopts those proposed by Japan's Public Works Research Institute; the relation for alluvium, which would seem appropriate for an area like Chashma, is given as:

$$A = 227.3 \times 10^{0.308M} (R + 30)^{-1.201}$$

where A is the acceleration (in cm/s^2), M the magnitude of the earthquake and R the distance between the earthquake epicenter and the site in km.⁶⁹

This relation between earthquake magnitude and ground acceleration, while intended for larger distances, serves to indicate that a large earthquake, of magnitude 7.0-7.5, on a fault 10 km from the Chashma site could produce a ground acceleration of about 0.39-0.55g.⁷⁰ An earthquake of similar size closer to the site, and certainly one directly below it, would generate far larger accelerations.

A seismic analysis of an unnamed reactor built on soft soil published by a PAEC engineer -- the attributes of this reactor and the site certainly suggest that it is Chashma -- cites the horizontal ground acceleration induced by a magnitude 7.0 earthquake as 0.25g.⁷¹ However, that analysis rather than calculating the acceleration from the size and distance of the earthquake and the soil properties, seems to simply adopt a value of 0.25g because that is the "design horizontal ground acceleration". Similarly, a peak ground acceleration of 0.25g was simply assumed in a structural analysis of a large overhead watertank at the nearby site of Kundian, where PAEC has built a number of nuclear facilities.⁷² These assumptions may reflect either a well-founded confidence in the maximum ground acceleration being no larger than the design value, or a reluctance to accept that the values used in the design may be exceeded.

⁶⁸ M. Ameen, *Seismic design analysis of reactor building of a PWR type nuclear power plant with the consideration of non-linearity of soil*, Individual studies by participants at the International Institute of Seismology and Earthquake Engineering, vol. 30, International institute of Seismology and Earthquake Engineering, Tsukuba, Japan, 1994, pp. 277-289.

⁶⁹ Y. S Ansari, *Seismic risk analysis of Pakistan*, Individual studies by participants at the International Institute of Seismology and Earthquake Engineering, vol. 31, International institute of Seismology and Earthquake Engineering, Tsukuba, Japan, 1995, pp. 103-115.

⁷⁰ The unit of acceleration, g, is the acceleration due to gravity, about 10m/s^2 .

⁷¹ M. Ameen, *Seismic design analysis of reactor building of a PWR type nuclear power plant with the consideration of non-linearity of soil*, Individual studies by participants at the International Institute of Seismology and Earthquake Engineering, vol. 30, International institute of Seismology and Earthquake Engineering, Tsukuba, Japan, 1994, pp. 277-289.

⁷² H. Maimed, *Seismic design example*, Bulletin of the International Institute of Seismology and Earthquake Engineering, 26, 1992, pp. 613-621.

It is not just large and very close earthquakes with a high ground acceleration that may be a danger at Chashma. There are some characteristics particular to the area that suggest smaller, more remote earthquakes which generate much lower ground accelerations could be a significantly greater danger to a structure there than to a comparable structure at a different location. Of particular concern is a phenomenon known as "liquefaction", in which under certain conditions an earthquake can induce the ground to deform and flow as if it had suddenly become a liquid.⁷³ The consequences of liquefaction can be extensive, severe and unpredictable in their details.

Historical examples show that the area which undergoes liquefaction can be very large and remote from the epicenter. In the 1964 Good Friday earthquake in Alaska, at Turanagain Heights (in Anchorage), liquefaction induced almost 3 km of the coastline to slide 300 m, while in the December 1811 New Madrid (Missouri) earthquake some 90,000 square kilometers were affected. This behavior can also occur at considerable distances from earthquake epicenters. In the 1976 Romanian earthquake, areas along the Danube River 400 km from the epicenter were subject to liquefaction.⁷⁴ In September 1985, Mexico City which is built on 800 m of silt and clay from an old lake bed, was struck by an earthquake 200 km away which created large scale liquefaction; as a result over 100,000 buildings were destroyed and 10,000 people were killed.⁷⁵

The effect of ground liquefaction on buildings and other structures depends on very local conditions. On gentle slopes, such as those found close to rivers, the "liquefied" soil can flow downhill, causing severe damage to the foundations of buildings and rigid structures like pipelines. On flat ground, the liquefaction can express itself as oscillations of the ground which cause rigid structures to fail, as well as a more general loss of strength which leads buildings to settle or tip over.⁷⁶

There are some guidelines for assessing whether an area should be characterized as a liquefaction hazard zone. One set suggests that, in cases where there is limited geological and geophysical data, areas susceptible to liquefaction should be taken to include "areas containing... current river channels and their historic floodplains, marshes and estuaries" where ground accelerations from earthquake could exceed 0.1g and the water table is less than about 12 m below the ground surface.⁷⁷

Chashma would seem to fit these criteria. It lies on the east bank of the Indus river, which is part of a larger system of rivers in that region. Beyond the several kilometers of the river's floodplains are the bar uplands, which occupy the majority of the area between the rivers, and can rise 15m above the flood plains. But these bar uplands are basically accumulations of silt and sand, and

⁷³ Earthquake Engineering Research Institute, *Liquefaction*,
http://www.eeri.org/EQ_Basics/LIQ/LIQUEFAC.html.

⁷⁴ B. A. Bolt, *Earthquakes*, revised edition, W. H. Freeman, New York, 1993, p. 13, p.164.

⁷⁵ Arizona - Princeton Earth Physics Project, *A Chronicle of Important Historical Earthquakes*,
<http://www.geo.arizona.edu/K-12/azpepp/education/history/>.

⁷⁶ Earthquake Engineering Research Institute, *Liquefaction*,
http://www.eeri.org/EQ_Basics/LIQ/LIQUEFAC.html.

⁷⁷ see for instance *Seismic hazards mapping program zoning guidelines - guidelines for delineating liquefaction hazard zones*, California Department of Conservation, Division of Mines,
<http://www.consrv.ca.gov/dmg/shezp/zon GUID/lq-zones.htm>.

sometimes clay.⁷⁸ The alluvial sand in these areas is porous, with an average porosity of about 0.35.⁷⁹

The Lamont-Doherty study referred to earlier suggested the possibility of a magnitude 7.0 or larger earthquake within 10 km of the site and any plausible inferred ground acceleration is likely to be far in excess of 0.1g. Even if the actual acceleration is the 0.25g design acceleration assumed in the PAEC calculation it still far exceeds the 0.1g proposed as appropriate for delineating the area as potentially at risk from liquefaction.

While extensive liquefaction is typically associated with large earthquakes (magnitude 6.6 and greater) the phenomena has also been induced locally by earthquakes with much lower magnitudes.⁸⁰ It has been suggested that the key requirement for a susceptible area to undergo liquefaction is that the peak horizontal ground acceleration equal or exceed a threshold value -- at one California site this threshold acceleration was 0.21g.⁸¹ It does not require a large earthquake to produce such acceleration; many earthquakes with magnitudes less than 5 have generated peak ground accelerations of this order.⁸²

Liquefaction is reportedly most common in areas where the water table is within 10 m of the surface, although there are a few instances of it occurring in areas with water tables deeper than 20 m.⁸³ The water table at Chashma is close to the surface, since it is located within a few kilometers from the Indus river and the Indus-Jhelum Link Canal. The proximity to the river and the Chashma-Jhelum Link Canal is such that the movement of ground water at the site is described as unstable.⁸⁴ It may be affected by the variation of water level in the canal. Furthermore, PAEC reports indicate that to permit construction to begin at the site the water table "in the project area" had to be lowered, and 42 tubewells were used for this purpose.⁸⁵ On a larger scale, due to intensive irrigation, the water table has risen from depths of 20-35 meters below the surface of the uplands adjoining the river until it is now only a few meters below the surface; near the river, the water table is almost at the surface.⁸⁶

The ground movement at Chashma may be made more severe and more difficult to predict by the effects of water on the soil. The presence of mud, rather than dry alluvium or rock, at a site can lead to significant localized amplification of the horizontal ground motion caused by an earthquake. This amplification can be sufficient to cause severe damage at large distances from

⁷⁸ H. Bender, *Water*, in *Geology of Pakistan*, eds. F. K. Bender and H. A. Raza, Gebruder Borntraeger, Berlin, 1995, p. 298-301.

⁷⁹ H. Bender, *Water*, in *Geology of Pakistan*, eds. F.K. Bender and H.A. Raza, Gebruder Borntraeger, Berlin, 1995, p. 302.

⁸⁰ C. J. Wills, *Liquefaction in the California desert*, *California Geology*, March/April 1996, <http://www.consrv.ca.gov/dmg/pubs/cg/96/96cgbarg.htm>.

⁸¹ T. L. Holzer, T. L. Youd, T. C. Hanks, *Dynamics of liquefaction during the 1987 Superstition Hills, California, Earthquake*, *Science*, 244, pp. 56-59, 1989.

⁸² T. L. Holzer, T. L. Youd, T. C. Hanks, *Dynamics of liquefaction during the 1987 Superstition Hills, California, Earthquake*, *Science*, 244, pp. 56-59, 1989.

⁸³ Earthquake Engineering Research Institute, *Liquefaction*, http://www.eeri.org/EQ_Basics/LIQ/LIQUEFAC.html.

⁸⁴ S.D. Hussain, M. Ahmed, M. Rafiq, N. Ahmed, *Measurement of groundwater flow velocity at CHASNUPP site using radio tracer technique*, PINSTECH/RIAD-125, Pakistan Institute of Nuclear Science and Technology, Islamabad, 1991.

⁸⁵ Pakistan Atomic Energy Commission, *Annual report 1992-1993*, Pakistan Atomic Energy Commission, Islamabad.

⁸⁶ H. Bender, *Water*, in *Geology of Pakistan*, eds. F. K. Bender and H. A. Raza, Gebruder Borntraeger, Berlin, 1995, p. 298-301.

an earthquake; the most dramatic recent example was in 1989 when the Loma Prieta earthquake induced the collapse of a freeway almost 100 km away in Oakland, near San Francisco. Subsequent investigation suggested that the mud underlying sections of the freeway may have amplified the local ground motion by a factor of 5 or greater.⁸⁷

The hazards discussed here do not include the possibility of earthquakes inducing a flood at the Chashma site or the natural flooding of the Indus river. The Indus river is prone to major flooding on a fairly regular basis, most recently there have been major floods in 1992, 1994, 1995 and 1998.⁸⁸ [See Map 7 for the areas inundated by flooding]. These floods can rise as high as 7 m.⁸⁹ The abandoned floodplains, further away from the river, are prone to more occasional flooding. These floods may extend to the Chashma site.

III: The Chashma Nuclear Power Plant

By building a reactor at Chashma PAEC has assumed that it has properly understood the risks at the site and correctly judged them to be acceptable. However, the likelihood that an earthquake may cause an accident at the reactor is also affected by the design of the particular nuclear power plant and the reliability of the components that have gone into it. There are questions about both.

Chashma is a pressurised water reactor (PWR) [see Figure 1], a design originally developed in the mid-1950s by the Westinghouse Corporation from a reactor it had built to power submarines for the US navy. It is now the most common type of nuclear power plant around the world.⁹⁰

In a pressurised water reactor,⁹¹ there is a core containing fuel made from Uranium which has been enriched so that it has a few percent of the isotope Uranium-235, instead of the 0.7% that occurs in nature. At Chashma, there are 36 tons of this fuel in the core, which has been enriched to contain 3.4% Uranium-235; the core itself is about 3 m tall and 2.5 m across. The Uranium-235 undergoes fission; the nuclei of the atoms break into fragments (fission products), that are themselves the nuclei of other, different, atoms along with neutrons and gamma radiation. The energy of the fragments becomes heat. To increase the chance of one of the neutrons that are created colliding with another Uranium nucleus and inducing another fission so producing further neutrons (i.e. sustaining a chain reaction), the neutrons are slowed down by passing them through a moderator -- which in a PWR is water. Chashma contains 57 tons of moderator.

In a PWR, the water also serves another role. The temperature of the fuel reaches hundreds of degrees centigrade, and this heat is removed by pumping high pressure water as a coolant through the core -- in this process the water is heated to about 300 degrees centigrade. The water is kept at very high pressure to prevent it from boiling. To maintain the high pressure, the core is put inside

⁸⁷ S. E. Hough, P.A. Friberg, R. Busby, E.H. Field, K.H. Jacob, and R.D. Borchardt, *Sediment-induced amplification and the collapse of the Nimitz freeway*, Nature, 26 April 1990, pp. 853-855.

⁸⁸ See the United Nations Office for the Coordination of Humanitarian Affairs (OCHA) relief web <http://www.notes.reliefweb.int/FILES/RWDomino.nsf/VNaturalDisastersTheLatest/53A2C91F0FF30660C12565BE00542076?>

⁸⁹ H. A. Raza and F. K. Bender, *Introduction*, in *Geology of Pakistan*, eds. F. K. Bender and H. A. Raza, Gebruder Borntraeger, Berlin, 1995, p. 4.

⁹⁰ For a history of how this happened see I.C. Bupp and J.-C. Derian, *Light Water: how the nuclear dream dissolved*, Basic Books, New York,, 1978.

⁹¹ For a description see F. J. Ran, A. G. Adamantiades, J. E. Kenton, C. Braun, *A guide to nuclear power technology- a resource for decision making*, Krieger Publishing Company, Malabar, 1992.

a giant steel pressure vessel through which this water is continuously pumped. There are two large primary coolant pumps, which pump 24,000 tons of water per hour into the pressure vessel and through the core, at a pressure of 155 kg/sq. cm. This hot, high pressure water is circulated through a series of pipes in a steam generator, where it heats up water surrounding these pipes to produce steam in a separate lower pressure water circuit. By giving up some of its heat to make the steam, the high pressure water cools and is then pumped back to the core. This cycle is the "primary system."

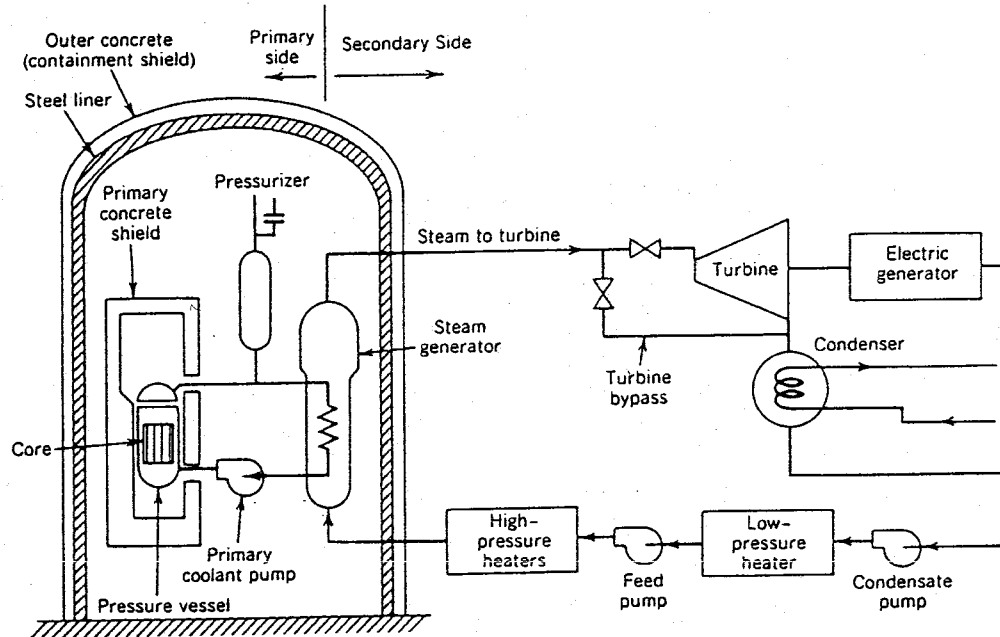

Figure 1: Schematic of a pressurised water reactor

[adapted from F. J. Rahn, A. G. Adamantiades, J. E. Kenton and C. Brann, *A guide to Nuclear Power Technology*, Krieger Publishing Company, Malabar, 1992, p. 267]

The steam that has been generated in the secondary loop is used to drive a turbine and a generator to produce electricity. The steam is cooled into water, by passing it through a condenser, and pumping it back to the steam generator to be reheated. The cooling water for the condenser is taken from an outside supply of water. In the case of Chashma, the cooling water is to be taken from the Chashma-Jhelum Link canal (at a rate of 25 m³/s) and the warm water from the condenser (about 5.5 C warmer than when it went into the condenser) is pumped into a small channel that runs for about 3 km before joining the Indus River. Over 60% of the heat produced in the core ends up as hot water that is discharged in this way. In case of an emergency, and a possible leak of contaminated water, the flow of hot water from the condenser is planned to be diverted to three cooling towers.

According to PAEC, the Chashma nuclear power plant is "designed, manufactured and constructed by the Chinese."⁹² While the China National Nuclear Corporation is the supplier of the Chashma nuclear power plant, the main contractor for the project is the China Zhongyuan

⁹² Pakistan Atomic Energy Commission, *Chashma nuclear power plant*, Pakistan Atomic Energy Commission, Islamabad, undated.

Engineering Corporation (CZEC). The Shanghai Nuclear Research and Development Institute (SNERDI) is responsible for design of the reactor, with the East China Electric Power Design Institute managing the conventional power generating side.⁹³

Chashma is based closely on China's Qinshan-1 nuclear power reactor (the technical specifications for Chashma and Qinshan-1 are given in Appendix 1). The chief designer of Chashma was Ouyang Yu, who took part in the work on China's first large-scale military production reactor and was the lead designer of the Qinshan-1 reactor.⁹⁴ [China has two small reactors dating from the 1960s for producing plutonium for its nuclear weapons program, at Jiuquan and Guangyuan, which may have ceased production in 1991.⁹⁵]

Qinshan-1 is often described in China and Pakistan as being an indigenous Chinese design. However, in trying to justify the safety of the design PAEC officials claim that Qinshan-1 is in fact "a basic but most proven Westinghouse design", and that "the Chinese improved the design to suit local conditions."⁹⁶ They do not say what those local conditions or improvements were. A less generous interpretation suggests that the improvements at Qinshan may have been because China "built the Qinshan reactor by copying those made by Westinghouse but had trouble obtaining detailed data."⁹⁷ The 1998 accident at Qinshan-1 (discussed in the next section) suggests that some of the Chinese attempts to make up for the missing Westinghouse design data may have had unexpected safety consequences.

The modifications introduced in the Westinghouse design to enable the building of Qinshan-1 mark the first step in the evolution of the Chashma design. CZEC, the main contractor for Chashma, has admitted that while Chashma is modeled on the Qinshan-1 reactor there have been some modifications, following visits in late 1992 by PAEC to the designers at SNERDI.⁹⁸ For its part, PAEC has claimed that "at the basic design review stage PAEC enforced numerous design improvements."⁹⁹ That changes had to be "enforced" may indicate that there was some dispute over them. This may also explain why in the spring of 1993 Ouyang Yu, the chief designer, along with six other Chinese nuclear engineers reportedly visited Pakistan "to resolve the outstanding issues of basic design".¹⁰⁰

Even after this visit the design continued to evolve, but not because of PAEC. In September 1993, an IAEA Design and Safety Review Mission visited Shanghai and Islamabad to perform an independent review of Chashma's design. According to PAEC, the IAEA Mission "made several recommendations for further improvements" in both the preliminary safety analysis and the

⁹³ Pakistan Atomic Energy Commission, *Annual report 1992-1993*, Pakistan Atomic Energy Commission, Islamabad.

⁹⁴ See the description given in Ho Leung Ho Lee Foundation: winners of the awards of technology progress 1995, <http://www.hlhl.org.cn/hlhl/e95.html>.

⁹⁵ D. Albright, F. Berkhout, W. Walker, *Plutonium and highly enriched Uranium 1996: world inventories, capabilities and policies*, Oxford University Press, New York, 1997, p.76

⁹⁶ Ahmed Irej Jalal, *Apprehensions of another kind*, The News, 13 August 1999, <http://www.jang.com.pk/thenews/aug99-daily/13-08-99/oped/o2.htm>.

⁹⁷ *China made nuclear reactor to resume operations in August*, Agence France Press, 5 July 1999

⁹⁸ Shahid-ur-Rehman Khan, *Chinese official says Chashma design is near complete*, *Nucleonics Week*, vol. 33, no. 51, p.8, December 17, 1992.

⁹⁹ Mirza Azfar Beg and Saeed A. Siddiqi, *Chashma nuclear power project*, Dawn, 21 November 1995.

¹⁰⁰ Pakistan Atomic Energy Commission, *Annual report 1992-1993*, Pakistan Atomic Energy Commission, Islamabad.

design.¹⁰¹ This suggests either SNERDI and PAEC had failed to identify some of the problems with the safety analysis and design of Chashma or that their solutions to some safety and design issues did not satisfy current international practice.

However, while the IAEA mission made "several recommendations for possible safety improvements in the design," PAEC reports that only "most" of them have been incorporated.¹⁰² There is no explanation of why only "most" and not all of the recommended changes were incorporated into the reactor. Nor is there any description of which of the proposed changes were deemed appropriate.

The PAEC inspired changes in Chashma's design and the later IAEA recommendations may be understood in light of the limited experience China's (and Pakistan's) nuclear power complex has with international standards for nuclear power plant safety. Substantively, this experience only dates to the mid-1980s when the United Nations Development Program and the IAEA began a training program for China's National Nuclear Safety Administration (NNSA), which includes the China National Nuclear Corporation. The IAEA claims that "through the provision of extensive expert services, the joint agency effort has fostered an enhanced 'safety culture' in the NNSA, especially in critical areas: nuclear power plant licensing; safety review of technical specifications; probabilistic safety assessment; accident analysis and accident management; reactor cooling systems; and power plant assurance inspection."¹⁰³

The lessons China's nuclear industry learned in these "critical areas" of safety were put to the test first at Qinshan-1. However, things may not be easier the second time round with Chashma. In addition to the changes in the design, there is another very significant difference between Qinshan-1 and Chashma.

The major components for Qinshan-1 were imported from established Western and Japanese nuclear industry suppliers; the reactor vessel came from Japan's Mitsubishi, the control system from Framatome in France, with other instrumentation and control equipment provided by Germany's Siemens, while Germany's Klein, Schanzlin & Becker provided the main pumps and valves.¹⁰⁴ This is not the case for Chashma. When approached for these components for Chashma, the suppliers refused.¹⁰⁵

The basis for the denial of Western and Japanese support for Chashma was laid at the March 31-April 3, 1992, meeting of the 27 countries that formed the Nuclear Suppliers Group (NSG).¹⁰⁶ At the meeting, it was agreed that there would be "a common policy of requiring fullscope safeguards to all current and future nuclear activities as a necessary condition for all significant,

¹⁰¹ Pakistan Atomic Energy Commission, *Annual report 1993-1994*, Pakistan Atomic Energy Commission, Islamabad.

¹⁰² Pakistan Atomic Energy Commission, *Chashma Nuclear Power Project: assurance of safety and Quality*, PakAtom- Newsletter of the Pakistan Atomic Energy Commission, May-June 1995, p. 5.

¹⁰³ IAEA, <http://www.iaea.or.at/worldatom/inforesource/other/iaeaun/chpfive.html>.

¹⁰⁴ Mark Hibbs, *No chance for Sino-Pakistan reactor deal, Western vendors say*, *Nucleonics Week*, vol. 33, no. 6, p.2, 2 February, 1992.

¹⁰⁵ Mark Hibbs, *No chance for Sino-Pakistan reactor deal, Western vendors say*, *Nucleonics Week*, vol. 33, no. 6, p.2, 2 February, 1992.

¹⁰⁶ The members of the NSG at that time were Australia, Austria, Belgium, Bulgaria, Canada, Czechoslovakia, Denmark, Finland, France, Germany, Greece, Hungary, Ireland, Italy, Japan, Luxembourg, Netherlands, Norway, Poland, Portugal, Romania, Russia, Spain, Sweden, Switzerland, United Kingdom and the United States.

new nuclear exports to non-nuclear weapon states.¹⁰⁷ Since Pakistan refused fullscope safeguards, it clearly did not meet the NSG condition.

Since Western and Japanese vendors would not supply the components for Chashma, China had to try to manufacture them for the first time. Given the limited Chinese capability to design and manufacture these components, Western nuclear industry experts claimed the Chashma project had "virtually no chance of success."¹⁰⁸ A US official went further, claiming Pakistan was trying "to import a reactor from a country which cannot supply it."¹⁰⁹

At least part of this judgement about the Chinese nuclear industry was borne out. China's efforts to manufacture the reactor pressure vessel apparently ran into trouble and South Korea's Korea Heavy Industries and Construction Company was asked to provide it.¹¹⁰ South Korea at that time was outside the NSG and not bound by the restriction to supply nuclear technology only to countries with fullscope safeguards. However, South Korea refused because it was seeking membership of the NSG.¹¹¹ Eventually, China's Fulaerji Heavy Mechanical Corporation took up the task of building the Chashma pressure vessel.¹¹²

There are doubts about the Chinese nuclear industry's capability of ensuring appropriate quality in its manufacturing. A 1997 description of China's nuclear industry by an academician of China's Academy of Engineering notes that "Chinese industry has acquired the capability for providing all equipment and apparatus for the nuclear power sector. Nonetheless, weak links linger in such fields as manufacturing technology, quality control and production management."¹¹³

The concern about quality control during manufacturing of the Chashma pressure vessel extends to include the accuracy of the testing of the pressure vessel, after it has been completed, to ensure it is of an appropriate standard. The Chashma pressure vessel was inspected by the China National Nuclear Corporation's Research Institute of Nuclear Power (RINPO).¹¹⁴ There is no information about what experience RINPO has in such inspections nor the results of the Chashma inspection.

The control system for Chashma was also designed and manufactured in China, by Beijing Helishi Automatic Engineering Co. It has been described as the "first such large-scale, high-tech product exported from China."¹¹⁵ This is not just the first export, it is the first time China has produced such a system. At the time the Chashma project was about to get underway, one Western nuclear industry supplier claimed "it is out of the question that China could reverse

¹⁰⁷ Nuclear Suppliers Group Plenary Meeting, 1992, http://projects.sipri.se/expcon/nsg_plenary92.htm.

¹⁰⁸ Mark Hibbs, *No chance for Sino-Pakistan reactor deal, Western vendors say*, Nucleonics Week, vol. 33, no. 6, p.2, 2 February, 1992.

¹⁰⁹ Mark Hibbs, *Pakistan feeling NSG pressure on supply for Chinese PWR export*, Nuclear Fuel, vol. 17, no. 15, p.13, 20 July, 1992.

¹¹⁰ Mark Hibbs, *South Korea could provide vessel for Pakistan's PWR*, Nucleonics Week, vol. 36, no. 38, p. 1, 21 September 1995.

¹¹¹ Mark Hibbs, *South Korea seeks NSG status, won't help China at Chashma*, Nucleonics Week, vol. 36, no. 39, p. 1, 28 September 1995.

¹¹² Shahid-ur-Rehman Khan, *PAEC details Chinese contractors for Chashma design, manufacture*, Nucleonics Week, vol. 36, no. 49, p.12, 7 December, 1995.

¹¹³ Qian Gaoyun, *Nuclear Power Offers Practical Supplementary Energy*, Beijing Review, <http://www.china.org.cn/bjreview/97Jan/97-2-13.html>.

¹¹⁴ *Chashma nuclear power plant to be commissioned soon*, Business Recorder, 31 August 1999, <http://www.brecorder.com/story/S--20/S2004/S2004107.htm>.

¹¹⁵ *China exports computer for Chashma plant*, Dawn 22 August 1997.

engineer and then supply main circulation pumps or an I&C [instrumentation and control] system for the project."¹¹⁶

China does not seem to have built on its experience of providing key components for Chashma. A 1996 report from the Chinese Nuclear Society claimed that, like Qinshan-1, the new reactors being built in China will depend on foreign suppliers for key components: the French reactor builder, Framatome, would supply reactor internals and instrumentation equipment, while South Korea was expected to provide the pressure vessels, and other key equipment.¹¹⁷ The Japanese company Mitsubishi was to provide the pressure vessel for Qinshan-2 and transfer technology to the Shanghai Boiler Works to allow it to construct the pressure vessel for unit 3. Mitsubishi was also to supply pumps for both units.¹¹⁸ Despite the experience gained with designing and building the control system for Chashma, China has also opted to purchase the computers for its new reactors at Qinshan.

The new reactors that are being built show that China has not persisted with the Qinshan-1 design. The two 600 MWe PWRs under construction, known as Qinshan phase II, are believed to be larger versions of Qinshan-1, and are described as "having been designed by Chinese experts with Western assistance."¹¹⁹ China may even be preparing to put aside its indigenous designs. For Qinshan phase III, China has purchased two 700 MWe CANDU reactors from Atomic Energy of Canada Limited.¹²⁰ Work is also soon to start on the first of two 1000 MWe Russian designed and built reactors at Lianyungang.¹²¹

The fact that the new reactors being built in China are of French, Canadian and Russian origin rather than being indigenous may explain why China is continuing to import key components despite having manufactured them for Chashma. The suppliers may have insisted on providing all the components. However, rather than being a purely financial concern this insistence may reflect concern about Chinese supplied components. China reportedly proposed that it would supply the pressure vessels for the reactors it intended to buy from France, but French nuclear industry experts refused, citing quality assurance concerns.¹²²

IV: The accident at Qinshan

China's experience with building and operating Qinshan has been far from ideal. The construction of Qinshan-1 took six years and "was riddled with problems and delays."¹²³ It was reported that Qinshan was delayed in its last year "mainly because the original planned time limit was too short, some installations arrived rather late, and it took some time to resolve problems in design

¹¹⁶ Mark Hibbs, *No chance for Sino-Pakistan reactor deal, Western vendors say*, *Nucleonics Week*, vol. 33, no. 6, p. 2. February 2, 1992.

¹¹⁷ Korea Heavy Industries & Construction Co. Ltd., (Hanjung), *Annual Report 1996*, <http://www.hanjung.co.kr/Report/report96/nuclear96.html>.

¹¹⁸ Atomic Energy Insights, http://ans.neep.wisc.edu/~ans/point_source/AEI/jul96/news_Jul96.html.

¹¹⁹ NucNet, 24 April 1996, <http://nucnet.aey.ch/nucnet/News/960424b.html>.

¹²⁰ AECL, <http://www.aecl.ca/cndue.htm#anchor5401507>.

¹²¹ Nuclear News, September, 1999.

¹²² Mark Hibbs, *PAEC official says China will make key parts, finish Chashma by 1999*, *Nucleonics Week*, vol. 38, no. 17, p. 3, 24 April, 1997 and M. Hibbs, *China's Equipment Makers Aim to Get pieces of nuclear deals*, *Nucleonics Week*, 9 April, 1998, p.14.

¹²³ Tai Min Chewing and Salaam Ali, *Nuclear Ambitions*, *Far Eastern Economic Review*, 23 January 1992, p. 12.

and installation which were revealed in testing."¹²⁴ As mentioned earlier, part of the problem may have arisen from the effort to integrate the modified Westinghouse design and locally made components with imported components from a diverse source of international suppliers.

Under a September 1990 nuclear cooperation agreement between China and Japan, China asked for Japanese experts in nuclear power plant safety to participate in the start-up of Qinshan-1.¹²⁵ They were on hand to assist because of concerns "about the safety of the plant, in which components from widely varying origins have been assembled without much advice from the vendors."¹²⁶ Incidentally, five Chashma engineers were present for the fuel loading and initial tests, including the first time the Qinshan reactor sustained a chain reaction.¹²⁷ Qinshan-1 first produced electricity in December 1991, but was closed in August 1992 for several months with suggestions that there were teething problems.¹²⁸ Among other problems, the uninterruptible power supply for the reactor's instrumentation was found to be unreliable and had to be replaced.¹²⁹

In July 1998, during the fourth refueling outage at Qinshan-1, what was said to be a routine inspection found that several dozen in-core instrumentation tube guides, that enter the reactor from below and allow detectors of various kinds to be inserted into the core, "had ruptured, apparently from vibrations, sending debris into the reactor vessel."¹³⁰ These pipes had been bolted in place, rather than the more normal practice of welding them, and the bolts on 24 out of the 30 pipes had been shaken loose by vibrations (presumably from the flow of the coolant), leading to nine of the 121 fuel assemblies being damaged and releasing radioactive material into the coolant.¹³¹

In August 1998, a month after the discovery of the damage to the core, the limited experience of the Chinese nuclear industry was further made evident. The Qinshan Nuclear Power Corporation, the operators of Qinshan-1, were forced to ask international nuclear engineering companies to assess the event, propose solutions and undertake repairs -- eventually giving the contract to the US company Westinghouse.¹³² It was reported that this was the first time Western nuclear industry experts were allowed inside the actual plant.¹³³

The problem at Qinshan appears to have been the result of poor design. It has been reported by Westinghouse engineers that the damage was due to "flow forces occurring during normal

¹²⁴ *Update on Status of Qinshan nuclear power plant*, Zhongguo Tongxun She, Hong Kong, 19 February 1991 (in Chinese), in JPRS-TND-912-004, 19 March 1991.

¹²⁵ *Japan to aid Qinshan startup*, Nuclear Engineering International, December 1990, p. 4

¹²⁶ Nucleonics Week, 18 October, 1990.

¹²⁷ Pakistan Atomic Energy Commission, *Annual report 1991-1992*, Pakistan Atomic Energy Commission, Islamabad.

¹²⁸ Shahid-ur-Rehman Khan, *Chinese official says Chashma design is near completion*, Nucleonics Week, vol. 33, no. 51, p.8, 17 December, 1992.

¹²⁹ Ouyang Yu, *Preparing Qinshan for full power*, Nuclear Engineering International, vol. 38, 1993, p. 30, on the web at http://www.insc.anl.gov/dbfiles/plant_info/oper_hist/Qinshan.html.

¹³⁰ Ann MacLachlan, *China's Qinshan-1 seeks solutions to vessel penetration ruptures*, Nucleonics Week, vol. 39, no. 50, p.1, 10 December, 1998.

¹³¹ *Nuclear reactor closed due to breakage*, Kyodo News Service, Tokyo, 4 July, 1999, from BBC Summary of World Broadcasts 6 July 1999.

¹³² Mark Hibbs, *Westinghouse aims to finish Qinshan-1 core repair by July*, Nucleonics Week, vol. 40, no. 15, p.6, 15 April, 1999.

¹³³ Ann MacLachlan, *China's Qinshan-1 seeks solutions to vessel penetration ruptures*, Nucleonics Week, vol. 39, no. 50, p.1, 10 December, 1998.

operation."¹³⁴ More specifically, it is claimed that "damage, in general, appeared to be primarily a result of design features which were not capable of withstanding normal operating flow loads".¹³⁵ This would suggest that when the reactor was designed the effect of the coolant flow on the core, pressure vessel and associated components was not sufficiently well understood by the designers. The components failed because they were inadequately designed for their operating requirement.¹³⁶

There is another failure indicated by the Qinshan-1 accident. It is not known exactly when the bolts shook loose and the core instrumentation tubes were damaged. The problem was detected during a routine refuelling shut-down, and may have occurred at anytime in the previous year -- i.e. since the previous re-fuelling. One reason for the delay in detecting the problem is that the Qinshan reactor lacked the acoustic monitors, required in US power plants, for listening to the core to provide early warning of unexpected vibrations that may indicate loose components.¹³⁷ The absence of these monitors in the Qinshan-1 reactor, which is now being rectified, would suggest that they were not a requirement that had been specified in the original reactor design. It is not known if these monitors were included in the requirements for Chashma, or what other, if any, early warning and diagnostic instrumentation for the core is included.

The contract with Westinghouse for repairs at Qinshan required the "design, analysis, fabrication and installation of replacement components."¹³⁸ This included "design improvements to provide a design that would survive for the remaining 20 year design life" of the reactor.¹³⁹ The repairs were completed in June 1999.¹⁴⁰ In the meantime, the China National Nuclear Corporation suggested that its engineers would modify Chashma to take care of the problem.¹⁴¹ There was no indication of how long would be the wait-and-see period to determine whether the repairs and design improvements at Qinshan-1 would work with the reactor with full power. Qinshan-1 was reported to have resumed operation in late September 1999.¹⁴² In November fuel loading began at Chashma. The wait-and-see period was barely a month. It is possible the modifications at Chashma were made before Qinshan resumed operation.

PAEC's business as usual response about Chashma in the wake of the Qinshan-1 incident is difficult to understand. It seems clear that an accident at Chashma requiring repairs to the core, while certainly beyond PAEC's capabilities to undertake, may also be beyond the capabilities of

¹³⁴ D. E. Boyle, M. A. Mahlab, *Taking a new view of internals repair at Qinshan*, Nuclear Engineering International, 30 October, 1999, p.16.

¹³⁵ D. E. Ekeroth, J.C. Matarazzo, D. H. Roarty, *Replacement component design for Qinshan unit 1*, Abstract, Eighth International Conference on Nuclear Engineering, <http://www.icone-conf.org/icone8/program/>.

¹³⁶ C. Yu, N. Singleton, Y. Weida, *Flow induced vibration loads on the vessel lower internals*, Abstract, Eighth International Conference on Nuclear Engineering, <http://www.icone-conf.org/icone8/program/>.

¹³⁷ Westinghouse Corporation, Personal communication, 1999.

¹³⁸ D. E. Ekeroth, J. C. Matarazzo, D. H. Roarty, *Replacement component design for Qinshan Unit 1*, Abstract, Eighth International Conference on Nuclear Engineering, <http://www.icone-conf.org/icone8/program/>.

¹³⁹ D. E. Ekeroth, J. C. Matarazzo, D. H. Roarty, *Replacement component design for Qinshan Unit 1*, Abstract, Eighth International Conference on Nuclear Engineering, <http://www.icone-conf.org/icone8/program/>.

¹⁴⁰ D. E. Boyle, M. A. Mahlab, *Taking a new view of internals repair at Qinshan*, Nuclear Engineering International, 30 October, 1999, p. 16.

¹⁴¹ Shahid-ur-Rehman Khan, *Qinshan-1 penetration ills won't delay Chashma start-up*, Nucleonics Week, vol. 40, no. 2, p.2, 14 January, 1999.

¹⁴² *China: Nuke plant running smoothly*, China Daily, World Reporter (TM) - Asia Intelligence Wire, 18 October 1999.

the Chinese suppliers. Unlike the case with Qinshan-1, US companies and other Western nuclear industry suppliers would not be able to offer assistance because of the restrictions on the supply of nuclear technology to Pakistan that follow from the guidelines adopted by the Nuclear Suppliers Group of countries and Pakistan's refusal to sign the Nuclear Nonproliferation Treaty.¹⁴³

This situation has been made more complex, especially in the United States, by the sanctions that were imposed on Pakistan after the May 1998 nuclear weapons tests. These sanctions required US government agencies to cancel "any activity, program, or training that contributes in any way to India or Pakistan's nuclear or missile capabilities". This restriction included "nuclear safety cooperation", with the only exception being a situation where "cooperation is essential in order to prevent or correct a radiological hazard posing a significant risk to public health and safety which cannot realistically be met by other means."¹⁴⁴

It is PAEC, and the government of Pakistan, that would have to make the initial assessment of a problem at Chashma that could both constitute a significant risk to public health and safety and be a problem that they could not deal with by themselves. In the absence of experience with PWRs and given the potentially unpredictable behavior of the Chashma reactor and its key components, even if there were warning of trouble it is not clear that PAEC could make an accurate assessment of the problem and possible implications in time to ask for help. It took only three and a half hours, between 4 a.m. and about 7:30 a.m. on March 28, 1979, for the Three Mile Island nuclear power plant to go from a normal operation to a state of "General Emergency". It took a further two days to realize how serious the accident had been and that radioactivity had been released into the environment. It took another month to stabilize the reactor and shut it down safely.¹⁴⁵

V: The Experience of Kanupp

PAEC's institutional experience in managing nuclear power will be crucial in determining how it assesses and manages the risks associated with Chashma over its planned lifetime of 40 years. This experience is dominated by PAEC efforts to operate Pakistan's only other nuclear power plant, the now nearly thirty years old Canadian designed and built Karachi Nuclear Power Plant (KANUPP).

The story of KANUPP is in some ways very similar to that of Chashma. On May 24, 1965, PAEC signed a turnkey project contract with Canadian General Electric for the design, supply, construction, and commissioning of a 137 MWe nuclear power plant. Pakistan had little or no input in designing or building KANUPP; according to Canadian General Electric managers "essentially all manufactured equipment was imported into Pakistan."¹⁴⁶ At the time, this was taken to reflect Pakistan's very limited nuclear capability, in terms of scientists, engineers and relevant industrial manufacturing capacity. Much the same seems to have happened with Chashma twenty-five years later.

¹⁴³ US Nuclear Regulatory Commission, private communication, August 1999.

¹⁴⁴ US Nuclear Regulatory Commission, private communication, August 1999.

¹⁴⁵ see D. F. Ford, *Three mile island: Thirty minutes to meltdown*, Penguin, 1981.

¹⁴⁶ R. J. Graham and J. E. S. Stevens, *Experience with CANDU reactors outside of Canada*, AECL, CNA-74-203, 1974.

KANUPP was to be Canadian General Electric's first and only attempt at designing and building a nuclear power plant. It received help with KANUPP from Atomic Energy of Canada Limited (AECL), which had designed and operated research reactors and the Nuclear Power Demonstration (NPD) and Douglas Point nuclear power stations. KANUPP is modeled on the Douglas Point and NPD reactors. Like them, it is a Canadian Deuterium Uranium (CANDU) reactor that uses natural uranium as fuel and heavy water as a moderator.

As part of the contract, AECL also agreed to provide fuel and heavy water for KANUPP and information on health and safety matters related to the reactor. AECL made an arrangement with PAEC, whereby AECL would provide the same support to PAEC as it had done to Canadian General Electric. This agreement was intended to last for the lifetime of the reactor.¹⁴⁷

As with Chashma, PAEC sent engineers to be trained by the reactor supplier. Even after KANUPP was inaugurated and responsibility for the plant technically transferred to PAEC in 1972, Canadian participation in the project continued through five advisers who were located at the plant.¹⁴⁸ KANUPP is also the home of the KANUPP Institute of Nuclear Power Engineering (KINPOE), and the In-Plant Training Centre (IPTC) which trains PAEC nuclear engineers and technicians. It is here that PAEC's reactor operators and plant managers largely have been trained.

It was India's nuclear weapons test in May 1974 that created a problem for the Pakistan-Canada nuclear relationship -- India used plutonium produced in a Canadian supplied reactor. This led to demands for greater safeguards on nuclear reactors. On 22 December 1976, Canada announced a new nuclear policy restricting support to states who had either ratified the Non-Proliferation Treaty or would otherwise accept fullscope safeguards covering their entire nuclear program.¹⁴⁹ Pakistan had not signed the Non-Proliferation Treaty and would not accept fullscope safeguards since that would have included its nuclear weapons related facilities. Consequently, Canada withdrew its support to Pakistan, which included suspension of all supplies of fuel, spare parts and technical assistance to KANUPP.

In 1972, soon after KANUPP was completed, commissioned, and had started to operate at full power, PAEC managers argued that the "exhaustive training" of their engineers and their participation in the design, operation and maintenance of the reactor alongside the Canadian suppliers meant that "the KANUPP operating team is fully capable of running the plant efficiently."¹⁵⁰ However, PAEC's assessment of the experience at KANUPP after six years of operation sheds a less flattering light on how it coped. It noted a "lack of proper pre-planned annual inspection programmes" and "equipment failures" most of which "might have been avoided if better quality control and assurance programmes had been implemented".¹⁵¹

The KANUPP operating experience review also admitted problems caused by "inadequate training of the operators". It noted, among other things, that "operational and testing jobs that require too frequent operation of switches at times resulted in maloperation leading to plant

¹⁴⁷ Agreement between the Government of Canada and the government of Pakistan relating to the construction of the Karachi Nuclear Power Station, Canada Treaty Series 1965, no. 26.

¹⁴⁸ R. J. Graham and J. E. S. Stevens, *Experience with CANDU reactors outside of Canada*, AECL, CNA-74-203, 1974.

¹⁴⁹ Ron Finch, *Exporting danger - A history of the Canadian nuclear energy export program*, Black Rose books, Montreal, 1986, p. 97.

¹⁵⁰ S. M. N. Zaidi, S. A. Khan, *Commissioning and early operation of Karachi nuclear power plant*, *The Nucleus*, vol. 9, nos. 3,4, July-December 1972, pp. 6-21.

¹⁵¹ S.D. Huseini, *KANUPP operating experience and maintenance and inspection programmes*, *The Nucleus*, vol. 16, nos. 3,4, July-December 1979, pp. 19-27.

outages." The lack of well trained and experienced operators familiar with the reactor control system showed up in the potentially most serious incident involving operator error that was reported. This was a case where "the operator forgot to transfer control of the reactor control rods to the controlling computer before allowing maintenance of the other computer".¹⁵² The control rods contain material that absorb neutrons and so regulate the reactor's power level and are used to shut it down quickly and safely in case of an emergency. Losing access to the control rods and not knowing it constitutes a serious lapse.

The history of KANUPP over its nearly thirty years of operation shows that it has consistently performed very poorly. International Atomic Energy Agency statistics show its lifetime energy availability factor (as of the end of 1997) was 28.6%, making it among the two worst performing nuclear power plants in the world; the Rajasthan Atomic Power Station, RAPS-1, a CANDU reactor in India of the same origin and similar age, has a slightly poorer performance with an availability factor of 23.1%.¹⁵³ Experience with the reactor seems to have brought little improvement in performance. For the period 1989-1996 KANUPP's capacity factor (the ratio of electricity actually fed to the grid in a given time to what could have been produced in that time if the plant had worked at its designed power) was only 34%.¹⁵⁴

The unplanned power shutdowns (outages) experienced by KANUPP offer some insight into the factors that are responsible for the poor performance. KANUPP has been shut down on average 1,243 hours (almost 52 days) each year between 1972-1997 because of equipment failure, and 83 hours (almost three and a half days) each year during the same period because of human error.¹⁵⁵ Although they may not all be directly safety related, such outages may offer an indication into the prevalence of unplanned situations and the corresponding inability of reactor operators to anticipate them and prepare accordingly. The lack of capacity to anticipate such recurring failures could be a crucial factor in the chain of events leading to an accident.

The chronic equipment failures at KANUPP may account for one PAEC manager's reported complaint that the plant became obsolete almost immediately after it was built.¹⁵⁶ These problems have grown to the extent that PAEC's report "25 Years of KANUPP", admits that "signs of normal ageing and obsolescence are becoming apparent. Many critical components are reaching the end of their designed life and need to be replaced."¹⁵⁷ It is worrying, however, that one nuclear industry journal has reported "many of KANUPP's ageing problems have been detected through catastrophic failure."¹⁵⁸

¹⁵² S.D. Huseini, *KANUPP operating experience and maintenance and inspection programmes*, The Nucleus, vol. 16, nos. 3,4, July-December 1979, pp. 19-27.

¹⁵³ For a plant operating at less than full capacity, the energy availability factor is defined as one minus the energy unavailability factor, which is the ratio of the energy which could have been produced by the missing capacity to the energy that would have been produced if the plant had been working at full capacity. See *Operating experience with nuclear power stations in member states in 1997*, IAEA, Vienna, 1998.

¹⁵⁴ G. Rothwell, *Comparing Asian nuclear power plant performances*, Pacific and Asian Journal of Energy, vol. 8, no. 1, pp. 51-64, June 1998.

¹⁵⁵ *Operating experience with nuclear power stations in member states in 1997*, IAEA, Vienna, 1998.

¹⁵⁶ J. Wood: *Life extension for Pakistan's Kanupp*; Nuclear engineering International, December 1991, pp. 54.

¹⁵⁷ KANUPP: 25 Years of Operation, PAEC, Islamabad, 1996.

¹⁵⁸ J. Wood: *Life extension for Pakistan's Kanupp*; Nuclear engineering International, December 1991, pp. 54.

One such catastrophic failure was in 1989, when there was a spill of 40 tons (one-third of the total) of heavy water, used to cool and moderate the reactor, which led to the reactor having to be shut down for several months.¹⁵⁹ It was later claimed there had been several earlier large spills that were covered up, with a former nuclear engineer from the plant claiming the staff at KANUPP were "ignorant of risk and think nothing of danger."¹⁶⁰

PAEC seems to have recognised the limitations of its capability to safely manage the reactor. In 1989, Pakistan joined the CANDU Owners Group (COG); established initially by AECL and Canadian power companies with CANDUs, this now includes CANDU operators around the world.¹⁶¹ Not long afterwards, COG signed a deal with PAEC to become the agent and manager of a "Safe Operation of KANUPP" project. The scope of the project suggested the range of areas where PAEC needed help; these included "physical inspections of the plant, as well as safety analysis of the original design using current techniques and standards" and "a radiological protection audit at KANUPP".¹⁶²

Possible safety problems at KANUPP and PAEC's need for help to deal with them is further suggested by the report that, following problems with a fuel channel at KANUPP, repairs were "successfully completed by KANUPP station staff under the supervision of an AECL CANDU site team." It appears that in one case supervision was not sufficient. The report notes that "during the same outage, AECL Research Chalk River Laboratories staff completed a series of inspections on eight fuel channels that had been recommended by an International Atomic Energy Agency (IAEA) Assessment of Safety Significant Events Team"¹⁶³

It was against this background that in 1992 Canada's nuclear regulatory agency, the Atomic Energy Control Board (AECB) considered safety issues at KANUPP. Since the AERB deals with the safe operation of Canada's own CANDU reactors it has the most experience with this design of any nuclear regulatory agency. Its records show that "in May 1992, the International Atomic Energy Agency sent the Government of Canada a report on the Canadian-built nuclear power reactor KANUPP, near Karachi in Pakistan. The report identified improvements needed to bring the reactor to an acceptable standard of safety. On the basis of the information in this report, and some additional information, AECB staff questioned how continued operation of the reactor could be justified, given the apparently serious safety problems." The AECB concluded that KANUPP's "continued operation is imprudent".¹⁶⁴

Rather than accept this recommendation and close down KANUPP, PAEC seems to have insisted on continuing to operate the plant. One reason to keep KANUPP going regardless of the risk may be contained in the admission from PAEC that "KANUPP is one major window for acquiring from the West the technology required to build nuclear power plants in the country".¹⁶⁵ Keeping KANUPP also provided a fig leaf for a range of activities that were key elements of the nuclear weapons program. The same logic may now be applied to Chashma.

¹⁵⁹ Pakistan Atomic Energy Commission, *Annual report, 1988-1989*, Pakistan Atomic Energy Commission, Islamabad.

¹⁶⁰ S. Rehman, *Pakistani press criticises KANUPP safeguards after plant restarts*, Nucleonics Week, 2 November, 1989.

¹⁶¹ CANDU Owners Group, *Annual report 1989*, p. 18.

¹⁶² CANDU Owners Group, *Annual report 1991*, cited on http://ccnr.org/india_pak_coop.html.

¹⁶³ W. M. Butt, M. M. Cobanoglu, *Fuel Channel Removal experience at KANUPP*, 15th Annual Conference Canadian Nuclear Association, vol. 2., p. 6, Canadian Nuclear Society Toronto, 1994.

¹⁶⁴ Atomic Energy Control Board, *Significant Development Report 1993 3*, 16 March, 1993, p.6.

¹⁶⁵ A. Alam, *Regime not to scrap Karachi nuclear plant*, The Muslim, 15 January 1993.

VI: Some concerns about an accident at Chashma

An earthquake affecting the Chashma site could cause a severe accident, especially if it is accompanied by liquefaction of the ground. The nature of the accident would determine the scale of any release of radioactivity from the core and the attendant damage to the environment and public health. A general description of a possibly catastrophic accident at a pressurised water reactor offers a context within which to look at some of the factors that may increase the chance of such an accident at Chashma.

The main barriers against radionuclide release to the environment from the radioactive fuel of a PWR are:¹⁶⁶

1. the solid fuel pellet
2. the metal cladding that surrounds the fuel
3. the reactor pressure vessel and primary water circulation system
4. the containment building

The first two of these barriers are sufficient during normal operation of the reactor to prevent significant release of radioactivity into the environment. The small ceramic pellets of uranium dioxide fuel (at Chashma these pellets are 1 cm long and about 0.85 cm across) are meant to retain most of the nuclear fragments (fission products) produced when the uranium nuclei break up. Since these fission products consist of many different elements and isotopes, which differ widely in their physical and chemical properties, there are some, especially the inert gases, which escape from the pellet.

To retain the fission products, and to allow water to carry away the heat generated by the fissioning fuel without coming into direct contact with it, the pellets are stacked one on top of another and encased in a long, leak-proof tube. These tubes are made from zircalloy; a family of zirconium alloys containing small but precise amounts (typically less than 1-2%) of chromium, nickel, iron, and tin which make the alloys strong, corrosion resistant, and able to withstand the several hundred degrees centigrade temperature of the fissioning fuel. Nevertheless, there is usually some leakage of fission products through the zircalloy into the coolant water. Some fraction of these radionuclides is eventually released into the environment as the radioactive liquid or gas effluent that nuclear power plants produce as an inevitable part of their operation.¹⁶⁷

For there to be a major accident involving the release of large amounts of radioactivity into the environment, the pressure vessel or coolant system and the containment have to fail.¹⁶⁸ A failure of the pressure vessel, or the coolant pumps, or a break in the coolant pipes can all lead to a loss of coolant accident (LOCA) that, in turn, could lead to the core overheating. If there is a LOCA and the emergency core cooling system fails to operate properly, or the pressure vessel breaks and cannot retain the emergency cooling water, the core may continue to overheat and eventually suffer a meltdown.

¹⁶⁶ Report to the American Physical Society of the study group on radionuclide release from severe accidents at nuclear power plants, (Draft), February 1985, p. 36.

¹⁶⁷ see for instance S. Glasstone and W.H. Jordan, *Nuclear power and its environmental effects*, American Nuclear Society, La Grange Park, 1980, pp. 238-262.

¹⁶⁸ For a description of reactor accident scenarios see Report to the American Physical Society of the study group on radionuclide release from severe accidents at nuclear power plants, (Draft) February 1985, p. 32-79.

The overheated and eventually molten core produces steam and other gases from the coolant. These increase the pressure inside the containment building. This pressure can rise sufficiently high that the containment can fail and radioactivity would be released to the atmosphere.

There are a number of ways in which the containment building can be breached, even though the building may be constructed of concrete with a steel lining.¹⁶⁹ The containment may simply fail because the pressure generated inside gradually increases until it exceeds the design value that was used to build it. Alternatively, the molten core may react with the steam to produce a steam explosion, which generates pressures high enough to crack the containment. Or, the containment building may not have been built to a sufficiently high standard because of poor quality materials and workmanship.

If the containment remains intact, it can be bypassed by the radioactivity escaping through any open vents or valves that are built into the containment walls, or by a break in the pipes that pass through the containment building walls. If some vent or valve through the containment has been left open radioactivity could escape even without a large build up of pressure. In all of these cases, there would be a release of radioactive material in the form of vapor to the atmosphere.

Independently of containment failure, the melting core would sink down through the concrete base of the reactor into the soil under the foundations.¹⁷⁰ This radioactive mass, after solidifying relatively quickly, would react slowly with the soil and radionuclides as well as the heavy metals from the core would be leached out by the groundwater, creating a very long lived hazard that may be spread over a large area.

This description can now be applied to Chashma. The first major concern about Chashma is the reactor pressure vessel. The pressure vessel at Chashma is a very large cylinder made from special steel, 10 m high, over 5.5 m in diameter, and 17.5 cm thick, and coated on the inside with a 4 mm thick layer of stainless steel [see Appendix 1]. Such vessels are made by welding together steel plates or forgings, which must be made to an exacting standard; including being free from chemical impurities, such as copper, sulfur and phosphorus, and free from any small cracks and flaws that may grow. This requires careful attention to the choice of the materials and the fabrication of the steel. The welds that hold the steel plates together must also be of a very high standard. The stainless steel coating must be carefully applied to limit corrosion of the pressure vessel by the very hot, high pressure coolant water it contains when the reactor is operating.

As mentioned earlier, the pressure vessel at Chashma is China's first effort, the pressure vessel for Qinshan-1 having been imported from Japan's Mitsubishi Heavy Industries -- which has been involved in supplying over 20 pressurised water reactors in Japan. It is also worth recalling that while trying to manufacture the Chashma pressure vessel the Chinese supplier had problems and more experienced international nuclear industry suppliers were asked to step in. It was when these suppliers refused that China was forced to complete the pressure vessel. At the same time, there are admitted weaknesses in both manufacturing technology and quality control in the Chinese nuclear industry.

¹⁶⁹ For the different kinds of containment problems see Report to the American Physical Society of the study group on radionuclide release from severe accidents at nuclear power plants, (Draft) February 1985, p. 73-75.

¹⁷⁰ For a description see Report to the American Physical Society of the study group on radionuclide release from severe accidents at nuclear power plants, (Draft) February 1985, p. 32-48.

The importance of the quality of manufacturing, assembly, and inspections of the pressure vessel grows over the several decades a nuclear power reactor is expected and designed to operate -- for Chashma this is 40 years. A particular concern is the embrittlement of the pressure vessel because of its exposure to the flux of neutrons that accompany the fissioning of the fuel in the core and leak out.¹⁷¹ This weakening of the pressure vessel depends on the detailed chemistry and metallurgy of the particular vessel and leads to an increased likelihood of fracturing rather than stretching to accommodate strains below a certain temperature. For instance, variations in the mean copper content of reactor vessel material of a few hundredths weight percent can significantly change how the vessel responds to embrittlement with time.¹⁷²

Embrittlement of the pressure vessel is also determined by the geometry and size of the core it contains, and the operating history of the reactor. The embrittlement that takes place over time in a pressure vessel is, in effect, "plant specific". On occasion this can be serious enough to require the closing of a nuclear power plant, most notably that of the Yankee Rowe nuclear power plant in New England in 1992.¹⁷³

The significance of pressure vessel embrittlement increases in the event of an accident. The sudden introduction of large amounts of cold water from the emergency core cooling system into the pressure vessel (where the water is usually over 300 C) produces a pressurised thermal shock as the pressure vessel begins quickly to cool. The thermal stresses produced by the rapid cooling, in addition to the normal high pressures in the pressure vessel, can lead to the vessel cracking.¹⁷⁴

Whether it is caused by a manufacturing defect, embrittlement or thermal shock, the implications of pressure vessel failure are severe. Such failure could render the emergency core cooling system ineffective, since the emergency cooling water, like the primary coolant, would escape from the pressure vessel.

There is also a question mark over the Chinese manufactured primary coolant pumps at Chashma. These pumps are responsible for keeping the very hot, high pressure water circulating through the core and steam generators and must be very reliable at the high temperature and pressure required for adequate core cooling. They must also be able to deal with the radioactivity that leaks inevitably into the coolant water from the fuel as a normal part of reactor operation. A failure of the primary pumps would lead to the core temperature rising and the internal pressure possibly increasing to beyond the pressure relief valve setting, and coolant water being lost through the valve. This depressurization of the core, or blowdown, if not stopped by the emergency core cooling system adding additional water, could be followed by a further loss of cooling water as the core turns more of it to steam (boiloff). This can eventually uncover the core (heatup) and lead to overheating and meltdown of the core.¹⁷⁵

There may also be a question about a third important component of the primary system at Chashma, the steam generator. This was supplied by China, while the steam generator at

¹⁷¹ R. Pollard, *US Nuclear Power Plants - Showing Their Age: Case Study: Reactor Pressure Vessel Embrittlement*, Union of Concerned Scientists, Cambridge, 1995.

¹⁷² US Nuclear Regulatory Commission, Technical Issues - Papers and Fact Sheets : *Reactor Pressure Vessel Embrittlement*, January 1999, <http://www.nrc.gov/OPA/gmo/tip/tip07.htm>.

¹⁷³ R. Pollard, *US Nuclear Power Plants - Showing Their Age: Case Study: Reactor Pressure Vessel Embrittlement*, Union of Concerned Scientists, Cambridge, 1995.

¹⁷⁴ R. Pollard, *US Nuclear Power Plants - Showing Their Age: Case Study: Reactor Pressure Vessel Embrittlement*, Union of Concerned Scientists, Cambridge, 1995.

¹⁷⁵ Report to the American Physical Society of the study group on radionuclide release from severe accidents at nuclear power plants, (Draft) February 1985, p. 44.

Qinshan-1 was supplied by the US company Babcock and Wilcox, which has manufactured more than 200 nuclear steam generators for power plants around the world.¹⁷⁶ The steam generator is typically one of the largest and most complex components of a nuclear power plant. Leaks in the pipes running through the steam generator would lead to the escape of primary coolant water and the resultant loss of core cooling. Thus, a poorly designed and manufactured steam generator could be important in initiating an accident.

The reliable operation of the control system is significant in maintaining the safe operation of the reactor in that it controls the active emergency core cooling system. PWRs have both passive and active emergency core cooling systems. The passive system typically relies on pressurised tanks of water (containing Boron to absorb neutrons) that is supposed to flood the core should the water pressure in the core fall below a certain value. This relies on pressure sensors and valves operating as specified. The active emergency core cooling system relies on pumps to maintain a high water pressure in the core should the primary pumps fail or water pressure start to fall because of a leak. These systems rely on the reactor control system to operate as designed. This does not always happen. The system can fail.

The breakdown of the control system can involve more than mechanical failure. Operator error involving the control system and the emergency core cooling system contributed to the Three Mile Island accident on March 28, 1979, which culminated in significant damage to the reactor core and a release of radioactivity to the environment.¹⁷⁷ This example shows clearly the extent to which nuclear reactor safety depends on more than design and reliable equipment.

Pakistani nuclear operators have no significant hands-on experience with PWRs, and to complicate matters the literature on which they depend for the design and operating procedures has had to be translated from Chinese. As part of the Chashma deal, 61 Pakistani engineers were to be sent to China for training in operating and maintaining the reactor, and a training simulator (a mock-up of the control room) of Chashma has been built.¹⁷⁸ While simulators and training to prepare for accidents are important, experience suggests such training in dealing with possible emergencies is limited by assumptions about the set of contingencies that may arise. The operators at the Three Mile Island plant had been trained on a simulator but it was discovered that "a case in which the entire emergency feedwater system is disabled simultaneously, as happened during the accident, was never programmed into the simulator."¹⁷⁹ More generally, the Three Mile Island simulator was set up only to provide training experience with accidents in which the emergency systems worked as designed.

This optimism may be even less reasonable in the case of Pakistan where, unlike the United States, there are not thousands of accumulated reactor hours of experience on similar reactors that can be used to try to create more realistic accident scenarios. It would seem reasonable to infer that the details of the scenarios in the Chashma simulator and in the Chashma operators' manuals are largely generic, while more detailed ones would be limited to experience accumulated over the six reactor years or so of operation at Qinshan-1.

¹⁷⁶ The Babcock & Wilcox Company, <http://www.babcock.com/pgg/ps/nuclear.html>.

¹⁷⁷ For details see D. F. Ford, *Three Mile Island: Thirty Minutes to Meltdown*, Penguin, 1981, pp. 13-22, and also T.H. Pigford, *The Management of Nuclear Safety: Lessons Learned from the Accident at Three Mile Island*, in *Nuclear Engineering in an Uncertain Future*, eds. K. Oshima, Y. Mishima, and Y. Ando, University of Tokyo Press, 1981, pp. 89-102.

¹⁷⁸ Pakistan Atomic Energy Commission, *Annual report, 1993-1994*, Pakistan Atomic Energy Commission, Islamabad.

¹⁷⁹ D. F. Ford, *Three Mile Island: Thirty minutes to meltdown*, Penguin, 1981, p. 156.

As the accident at Three Mile Island showed, optimism about everything working as designed during an emergency may be unfounded. A simple example is a possible loss of off-site power, the situation where access to the grid is lost and usually means that the main turbine and generator of nuclear power plant cannot be used to provide power to cool the core. The reactor then relies on diesel generators to keep the coolant circulating, and their reliability becomes crucial in the safe operation of the plant. The probability of a loss of off-site power at a nuclear power plant in the US is cited as about once every eight years.¹⁸⁰ The same assumption does not hold for Pakistan where sudden breakdowns of the electricity supply system occur repeatedly each year, sometimes across very large areas. KANUPP, for instance, has shut numerous times, for a total of 100 days between 1972-1998, because the electricity grid was unavailable.¹⁸¹ The likelihood of a loss of off-site power during an emergency caused by some other problem would make managing the reactor that much more difficult and accident-prone.

It is not only the different reactor design, components, levels of operator experience and training, or the accuracy of the simulator, or the larger technological infrastructure within which the nuclear power plant is embedded that shape the risk. In the case of Chashma, there are questions about how effectively detailed practices such as nuclear reactor operations can be transferred across cultures and institutions that are significantly different. A comparative study of PWR staff, especially control operators, in the United States, Germany, France, Switzerland and Sweden concluded that the impact of local social, cultural and institutional norms could be significant. The study reported that "the general social and cultural environment" could shape behavior that was "central and functional to operational safety and reliability".¹⁸² In Pakistan, the spill over of social and cultural norms into the management of high technology systems seems evident in the poor performance of the power generation and transmission system, the national airline, etc.

VII: Chashma core radionuclide inventory and possible release

It is possible to make a simple preliminary estimate of the consequences of a major loss of coolant accident in which the core melts down, the containment is breached and a significant fraction of the radioactive inventory of the core is released to the atmosphere. This is the most severe kind of reactor accident. The assessment of radionuclide release and dispersion, and possible health effects will rely on the treatment developed in the 1975 report of the American Physical Society study group on light water reactor safety.¹⁸³ This independent study exposed some of the very conservative assumptions used by the US nuclear industry in assessing the consequences of such an accident.

A large number of fission products are produced when nuclear reactions take place. The detailed inventory of these radionuclides varies depending on reactor design, fuel composition and the burn-up of the fuel. Since the composition, enrichment and design burn-up of the Chashma fuel is typical for a PWR, a simple scaling down of the inventory calculated for a reference 1000 MWe

¹⁸⁰ F. J. Rahn, A. G. Adamantiades, J. E. Kenton and C. Brann, *A guide to Nuclear Power Technology*, Krieger Publishing Company, Malabar, 1992, p.764.

¹⁸¹ International Atomic Energy Commission Power Reactor Information System, <http://www.iaea.or.at/programmes/a2/>

¹⁸² G. I. Rochlin and A. von Meier, *Nuclear power operations: a cross-cultural perspective*, Annual Review of Energy and Environment, 19, pp. 153-187, 1994.

¹⁸³ Report to the American Physical Society by the study group on light water reactor safety, Reviews of Modern Physics, Vol. 47, Supplement No. 1, 1975.

PWR offers an adequate approximation to the abundance of the 43 most important radionuclides in the Chashma reactor core in its steady state operation.¹⁸⁴ [see Appendix 3]

When an accident occurs, only a fraction of the total core inventory of radionuclides is released to the atmosphere. The fraction released varies for different isotopes. The same fractional release is assumed as was used in the American Physical Society study.¹⁸⁵ [Appendix 3 gives the core inventory, the fraction assumed released to the atmosphere and the total amount of radionuclides presumed released from Chashma.]

The errors in such estimates could be significant. The non-inert gas radionuclides released from the fuel react chemically with both the steam-hydrogen mixture generated by core melting heating the coolant water and the molten zircalloy cladding of the fuel rods. These radionuclides are then dispersed in the pressure vessel and coolant system and undergo complex condensation behavior on exposed surfaces and on pre-existing aerosols, as well as forming new aerosols, which in turn agglomerate. All these processes occur in a rapidly changing atmosphere that includes vapors and aerosols produced from the heating of the core and other structural materials. Since the pressure vessel cannot contain a core meltdown, there are further chemical reactions in the containment building, depending on the type of containment. There are no accurate models of many of these processes, while experimental data from laboratory experiments is limited and in some cases unavailable.¹⁸⁶

The only real data on the massive release of radioactivity from a reactor core comes from the terrible accident on 26 April 1986, at the 950 MWe Chernobyl reactor in Ukraine. This has been the only accident where there was a major fuel meltdown and an uncontrolled release of a large amount of radioactivity to the atmosphere. Analysis of the data on deposited radionuclides combined with studies of the core debris and the deposited material within the reactor building have provided the basis for an assessment of the actual release.¹⁸⁷ However, despite these measurements and a decade of detailed study, the IAEA's director of Radiation and Waste Safety reports that "there is no complete consensus on the amount of radioactive material released by the Chernobyl accident."¹⁸⁸

Rather than compare all 43 radionuclides, it is sufficient to focus on those which most impact human health. These are certain isotopes of Iodine, Cesium and Strontium. Iodine is readily absorbed by the human body after inhalation or ingestion and is concentrated in the thyroid; Iodine-131 is the more significant isotope. Cesium-137 and Strontium-90 are long-lived, with half lives of about 30 years. They are the important contributors to the radiation dose received by people because of the penetrating gamma rays associated with Cesium-137 and the efficient way Strontium enters the food chain.

¹⁸⁴ Report to the American Physical Society by the study group on light water reactor safety, *Reviews of Modern Physics*, Vol. 47, Supplement No. 1, 1975.

¹⁸⁵ Report to the American Physical Society by the study group on light water reactor safety, *Reviews of Modern Physics*, Vol. 47, Suppl. No. 1, 1975.

¹⁸⁶ Report to the American Physical Society of the study group on radionuclide release from Severe Accidents at Nuclear power Plants, (Draft), February 1985, p. 99.

¹⁸⁷ see for instance *Chernobyl 10 Years On: Radiological and Health Impact - An Assessment* by the NEA Committee on Radiation Protection and Public Health, OECD Nuclear Agency, November 1995, <http://www.nea.fr/html/rp/chernobyl/allchernobyl.html#chap2>.

¹⁸⁸ Abel J. Gonzalez, *Chernobyl - Ten Years After*, IAEA Bulletin, vol.38, no. 3, 1996, pp.2-13.

Table I: Fractions of total core inventory of some significant isotopes assumed released to atmosphere in the 1975 APS accident study and for Chashma and estimated for the 1986 Chernobyl accident

| Isotope | Assumed fraction (%) released in APS accident study ¹⁸⁹ and from Chashma | Estimated fraction (%) released from Chernobyl ¹⁹⁰ |
|-------------|---|---|
| Inert gases | 90 | 100 |
| Strontium | 2 | 4-6 |
| Iodine | 70 | 50-60 |
| Cesium | 30 | 20-40 |

The only significant difference in the fractions estimated to have been released is for the case of Strontium. This difference may have been due to the graphite moderator of Chernobyl having caught fire during the accident and creating an additional source of fuel particles, with the Strontium that was present sticking to these particles and being carried out of the plant.¹⁹¹

By combining the initial core inventory of radionuclides with the fraction that would be released it is possible to estimate the total amount of each isotope that would be released to the environment in a catastrophic accident. Table II compares the radioactivity of the most significant radionuclides released from an accident at Chashma with the estimated total amounts of these radionuclides used in the PWR accident study by the American Physical Society and with the amounts estimated to have been released from Chernobyl. It would seem that the values for Chashma are within the right order of magnitude, given the three times larger power rating of Chernobyl and the reactor used in the APS study.

¹⁸⁹ Report to the American Physical Society by the study group on light water reactor safety, *Reviews of Modern Physics*, Vol. 47, Supplement No. 1, 1975, table XI, p. S48.

¹⁹⁰ *Chernobyl 10 Years On: Radiological and Health Impact - An Assessment* by the NEA Committee on Radiation Protection and Public Health, OECD Nuclear Agency, November 1995, <http://www.nea.fr/html/rp/chernobyl/allchernobyl.html>.

¹⁹¹ *Chernobyl 10 Years On: Radiological and Health Impact - An Assessment* by the NEA Committee on Radiation Protection and Public Health, OECD Nuclear Agency, November 1995, <http://www.nea.fr/html/rp/chernobyl/allchernobyl.html>.

Table II: A comparison of the assumed radioactivity release from Chashma with that assumed in the APS study for an accident at a 1000 MWe reactor and the estimated release from Chernobyl¹⁹²

| Isotope | Total release in the APS study (megacuries) ¹⁹³ | Total release from Chashma (megacuries) | Total released from Chernobyl (megacuries) |
|-------------------|--|---|--|
| ⁹⁰ Sr | 0.31 | 0.09 | 0.3 |
| ¹³¹ I | 59.5 | 18.03 | 47.5 |
| ¹³⁷ Cs | 2.9 | 0.88 | 2.3 |

VIII: The wedge model for atmospheric dispersion

The dispersal of radioactivity in the atmosphere following a reactor meltdown and breach of containment is a complex phenomenon. However, it has been shown that a simple wedge model in which the released cloud of radioactive gases and small particles mixes quickly with the air to form a more or less stable front that extends down to the ground and widens as it moves away from the accident site.¹⁹⁴ It offers a reasonable approximation to the dispersal of radioactivity to large distances and is adequate for estimating the radiation dose that will be received by people.

In the wedge model, illustrated in Figure 2 below, a radioactive gas and aerosol cloud carrying Q curies of radioactivity travels away from the point of release propelled by a wind of velocity u , and diffuses perpendicular to the wind direction at a constant rate to form a wedge with opening angle θ . The vertical thickness of the wedge is H and the radionuclide aerosol is deposited on the ground out of this uniform density wedge at a settling velocity v_d .

¹⁹² *Chernobyl 10 Years On: Radiological and Health Impact - An Assessment* by the NEA Committee on Radiation Protection and Public Health, OECD Nuclear Agency, November 1995, <http://www.nea.fr/html/rp/chernobyl/allchernobyl.html>.

¹⁹³ Megacuries are millions of curies, the unit describing the radioactivity of an amount of material. One curie is equal to 37 billion nuclear disintegrations per second.

¹⁹⁴ Report to the American Physical Society by the study group on light water reactor safety, *Reviews of Modern Physics*, Vol. 47, Supplement No. 1, 1975, p. S97.

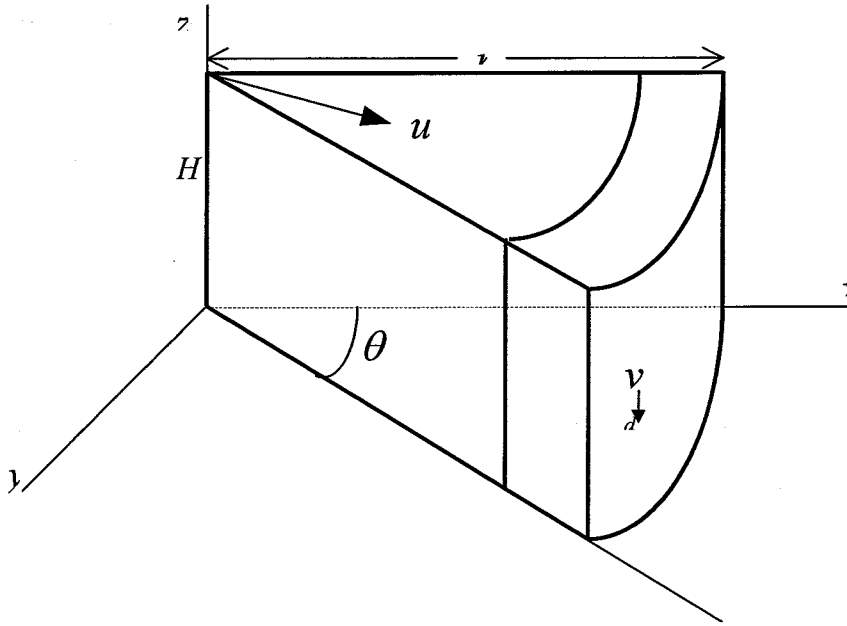

Figure 2: Schematic of the wedge model

The time-integrated concentration of radioactivity in the wedge (in curies-sec-m⁻³) at a distance r in meters, allowing for the decay of isotopes during transport, is:¹⁹⁵

$$\chi(r) = \frac{Q}{Hu\theta} \frac{e^{-\left(\frac{v_d}{H} + \lambda_d\right)\frac{r}{u}}}{r}$$

Where Q is the initial total release of each isotope (in curies) and $Qe^{-\left(\frac{v_d}{H} + \lambda_d\right)\frac{r}{u}}$ is the amount to be found at a distance r (meters) away from the source taking into account the aerosol deposition (and hence depletion from the plume) at the rate of v_d (m/s), and decrease in radioactivity with time with the decay rate of λ_d (s⁻¹). Here H is the thickness of the wedge (meters), θ is the wedge opening angle and u is the wind velocity (assumed constant and unidirectional, in meter/sec).

The thickness of the wedge will depend on the height of the release of radioactivity, the height of the plume, the atmospheric stability and other properties of the local topography and weather. However, at large distances and over periods that are long compared to the release time, this

¹⁹⁵ Report to the American Physical Society by the study group on light water reactor safety, Reviews of Modern Physics, Vol. 47, Supplement No. 1, 1975, eq. A-II-16, p. S97.

released radioactivity may disperse throughout the mixing layer of the lower atmosphere by diffusion. Following the APS study H is taken to be a median value for the atmospheric mixing layer thickness, about 1100 meters.¹⁹⁶ For comparison, the plume of radioactive fission products, smoke, and debris released from Chernobyl was about 1 km high.¹⁹⁷

The effective wedge angle is a measure of the horizontal dispersion of the plume of radioactivity released from the reactor. Depending on the stability of atmosphere, it can range from 0.1 to 0.7 radians, and following the APS study, the median value adopted for the plume opening angle is 0.25 radians.¹⁹⁸

The deposition velocity for the radionuclide aerosol depends on aerosol size, composition, wind speed, terrain and ground cover, humidity, the presence of rain, etc. The deposition velocity v_d may range from 10^{-5} m/s for dry deposition to 0.1 m/s for wet deposition.¹⁹⁹ Following the APS study, dry deposition is assumed. The effect of adsorption of radioactive gases onto the ground is ignored.

The assumed deposition velocity for different isotopes in the aerosol, following the values taken in the APS study, is given in Table III below.

Table III: Deposition velocities assumed for different families of radionuclides²⁰⁰

| Isotope | Deposition velocity (m/s) |
|----------------|------------------------------|
| Noble gases | 0.0 |
| Iodines | 0.005 |
| Other isotopes | 0.002 |

The model of dry deposition assumed here leads to a uniform contamination of the ground. Rain can change the deposition enormously, creating local hotspots where deposition and thus radiation levels are much greater. The data from the Chernobyl accident shows that the amount of radionuclides deposited by rain is approximately proportional to the amount of rain and may be significantly greater than the dry deposition.²⁰¹

¹⁹⁶ Report to the American Physical Society by the study group on light water reactor safety, Reviews of Modern Physics, Vol. 47, Supplement No. 1, 1975, p. S97.

¹⁹⁷ *Chernobyl 10 Years On: Radiological and Health Impact - An Assessment* by the NEA Committee on Radiation Protection and Public Health, OECD Nuclear Agency, November 1995, <http://www.nea.fr/html/rp/chernobyl/allchernobyl.html>.

¹⁹⁸ Report to the American Physical Society by the study group on light water reactor safety, Reviews of Modern Physics, Vol. 47, Supplement No. 1, 1975, p. S97.

¹⁹⁹ US Nuclear Regulatory Commission, *Reactor Safety Study: An Assessment of Accident risks in U.S. Commercial Nuclear power Plants*, WASH-1400 (NUREG 75/014), Appendix VI: Calculation of Reactor Accident Consequences, Appendix B, table VI B-1, p. B-9.

²⁰⁰ Report to the American Physical Society by the study group on light water reactor safety, Reviews of Modern Physics, Vol. 47, Supplement No. 1, 1975, table XII, p. S49.

²⁰¹ *Radioactive Contamination in the Netherlands as a result of the Nuclear Accident at Chernobyl*, Coordinating Committee for Monitoring of Radioactive and Xenobiotic Substances (CCRX), Ministry of Housing, Physical Planning and Environment, The Hague, October, 1986, p 37.

The remaining free parameter in the wedge model is the wind velocity u . The wind speeds used here were obtained from the Global Gridded Upper Air Statistics (GGUAS) master data base. This data set describes the atmosphere for each month of the year with a spatial resolution of approximately 100 km in the middle latitudes and was derived from data for 1980-1995.²⁰² It seems reasonable to use this data since it does not reflect the winds in the immediate surroundings of the Chashma site but rather the wind speeds and directions over a large area. It has been used to generate the average monthly ground surface wind speeds in eight 45° horizontal sectors around Chashma.

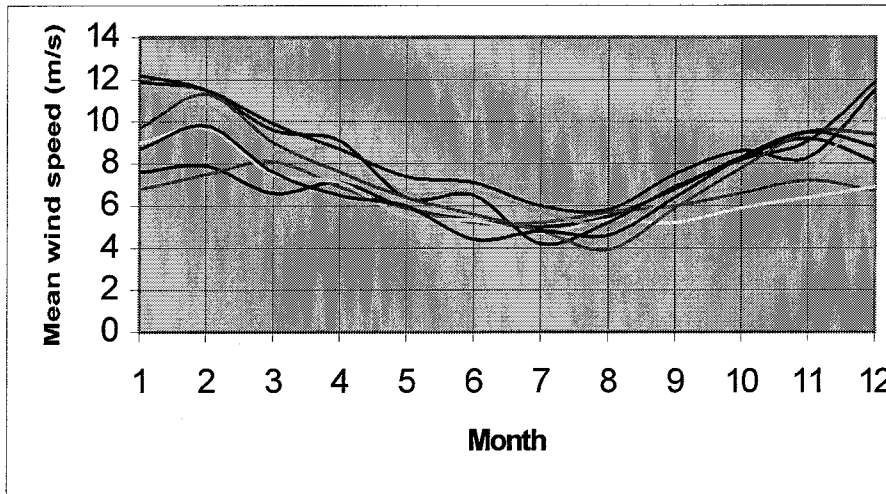

Figure 3: Mean monthly wind speeds at Chashma

The data suggests considerable variability in the wind speed for any given direction over the year. But, for most of the months and in most directions, the winds have magnitudes between 4 and 8 m/s. An average wind speed of 6 m/s is assumed.

The same data is shown in Table IV to indicate the frequency with which the wind blows towards particular directions in the Chashma area. For most of the time the winds in Chashma are westerly or south-westerly, but during some months they are predominantly eastwards, north-easterly and south easterly, i.e. blowing towards more populous regions (see Section IX below for a discussion of population distribution).

²⁰² We are grateful to M. McKinzie at the Natural Resources Defense Council for providing this.

Table IV: Percentage occurrence of winds blowing towards various directions in different months at Chashma

| Direction → | N | NE | E | SE | S | SW | W | NW |
|-------------|------|------|------|------|------|------|------|------|
| January | 6.3 | 3.7 | 2.6 | 3.5 | 11.9 | 21 | 31.1 | 19.8 |
| February | 6.6 | 5.8 | 4.5 | 7.9 | 13.9 | 18.1 | 25.3 | 17.9 |
| March | 5.9 | 4.6 | 6.5 | 9.8 | 13.7 | 22 | 24.1 | 13.5 |
| April | 13.1 | 11.9 | 8.4 | 6.2 | 14.5 | 21.8 | 12 | 11.9 |
| May | 11 | 8.7 | 8.5 | 8.7 | 15.7 | 20.4 | 15 | 11.9 |
| June | 5.2 | 7.1 | 12.8 | 12.9 | 16 | 22 | 15 | 8.8 |
| July | 7.8 | 11.1 | 17.3 | 18.8 | 16.7 | 15.8 | 6.6 | 4.4 |
| August | 6.8 | 12 | 23.8 | 20 | 11.6 | 10.3 | 9.5 | 5.1 |
| September | 12.4 | 14.8 | 9.8 | 10 | 13.8 | 18.3 | 9.8 | 10.5 |
| October | 12.8 | 21 | 9.2 | 7.9 | 10.7 | 16.4 | 9.7 | 12.3 |
| November | 14.2 | 9.2 | 8.9 | 8.1 | 13.3 | 14.2 | 12.5 | 18.9 |
| December | 6.6 | 6.2 | 4 | 6.5 | 12 | 21.3 | 26.2 | 17.3 |

In summary, the value of the parameters chosen for the wedge model calculations are:

Initial radioactivity released Q : as given in Appendix 3

Wedge height H : 1100 m (taken from the APS study)

Wind speed u : 6 m/s (average wind speed at Chashma)

Deposition velocity v_d : from Table III

Wedge opening angle θ : 0.25 radians (taken from the APS study)

Decay constant λ_d from the half-lives of the isotopes (standard values)

The subsequent calculations are limited to the effects of the dispersal of radioactivity out to a distance of 300 km from Chashma. This has been assumed because it is roughly the distance to Pakistan's border with India on the east and with Iran and Afghanistan in the west. It is important to note that the radioactivity may travel much further than this. The APS study used a distance of 800 km in its assessment.²⁰³ Appendix 4 presents the time-integrated concentration of radioactivity in the wedge, χ , for each isotope as function of r at distances of 10 km, 100 km, and 1000 km to illustrate the evolution of radioactivity in the wedge. The results suggest that even at a distance of 1000 km from Chashma, there would be significant radioactivity within the cloud.

IX: Population and population density

A key parameter in assessing the large scale health effects of the cloud of radioactivity that could be released from an accident at Chashma is the population density in the affected areas.

The provisional results from the 1998 census of Pakistan, which have been contested, give an official figure for the total population of Pakistan of about 130.5 million.²⁰⁴ The country has an area of roughly 796,095 square km. This gives an average national population density of about 164 persons per square kilometer. However, there is enormous geographic variation in the population density; the single largest province of Pakistan, Balochistan, with 43.6% of the total

²⁰³ Report to the American Physical Society by the study group on light water reactor safety, Reviews of Modern Physics, Vol. 47, Supplement No. 1, 1975, p. S106.

²⁰⁴ *A nation of 130 million*, Dawn, 10 July, 1998.

area has barely 5% of the population. Allowing for this gives an effective population density for the rest of Pakistan of 276 persons per square kilometer.

Provisional figures from the 1998 census are only presently available for some of the largest cities and the districts incorporating them. [see Appendix 5] It can be seen that local population density, especially in the Punjab province in districts within 100-300 km of Chashma is typically between 500-600 persons/km². Provisional census population figures are not available for the districts immediately bordering on Chashma (which is in district Mianwali), namely Bhakkar, D. I. Khan, Bannu, Karak, Kohat, Attok, Chakwal and Khushab. A rough sense of these figures can be gained by using the 1981 population and population densities for these districts and scaling them to give approximate population and population densities for 1998.

Table V: Estimated population density of the districts immediately around Chashma

| District | Population 1981 | Population density persons/sq. km 1981 | Estimated 1998 population density persons/sq. km |
|------------|-----------------|--|--|
| Attok | 1,144,000 | 116.9 | 188 |
| Chakwal | 368,000 | 140.4 | 226 |
| Bannu | 711,000 | 161.9 | 260 |
| D. I. Khan | 635,000 | 70.6 | 113 |
| Kohat | 358,000 | 140.7 | 226 |
| Karak | 214,000 | 63.4 | 102 |
| Bhakhar | 666,000 | 81.7 | 131 |
| Khushab | 646,000 | 98.9 | 159 |
| Mianwali | 1,377,000 | 98.4 | 158 |

It can be seen that the immediate areas around Chashma have a substantially lower population density than the more fertile areas of central Punjab which are at distances greater than about 100 kilometers and have a population density somewhat greater than 500 persons per square kilometer.

However, this low average population density conceals areas of much higher density. It has been reported that very close to the Chashma site is a settlement of a few thousand inhabitants, who are mainly working in the PAEC facilities in the region, and about 7 km from the site there is the town of Kundian with around 25,000 inhabitants.²⁰⁵ Then there is Mianwali city, 30 km or so from the site. There are also Afghan refugee camps in Mianwali district.²⁰⁶ The population in this in the area may grow significantly faster than the national average over the life-time of the Chashma reactor, especially if the proposed large hydroelectric and irrigation dam is built at Kalabagh, about 40 km north of Mianwali.²⁰⁷

²⁰⁵ F. W. Kruger: *Adapting planning to conditions in developing countries*; Nuclear Engineering International, May 1993, pp. 25-27.

²⁰⁶ *Income Generating Project for Refugee Areas: Pakistan Impact Evaluation Report*, The World Bank, <http://www.worldbank.org/html/oed/15862.htm#IGPRA>.

²⁰⁷ Beena Sarwar, *Kalabagh ignites political discord*, Inter-Press Service, http://www.oneworld.org/ips2/june98/09_16_034.html.

For the purposes of the calculation, the population density is assumed to be 500 persons per square kilometer. This estimate reflects the existing population density in the more populous areas to the east of Chashma, and allows for the roughly 2.5% per annum rate of growth of Pakistan's population which will lead to a more than doubling of the total population over the reactor's planned lifetime.

The other significant feature of the Pakistani population is that a very large fraction of it is quite young. The high rate of population growth has meant that about 54% of the population is now below the age of 19 while 32% is under the age of 10.²⁰⁸ This young population assumes significance because there is good evidence that the age at which exposure to radiation takes place can influence the potential health effects. It is well known that children are particularly susceptible to thyroid cancer, while young women exposed to radiation, especially those under 20 years of age, are at a significantly higher risk of breast cancer than older women.²⁰⁹

Planning for nuclear accidents and the capacity to promptly evacuate large numbers of people from the areas around a nuclear reactor accident site can go some way to reducing the effects on public health. However, as shown earlier the cloud of radioactivity will travel hundreds of kilometers and evacuation to that distance is impractical.

In the case of Pakistan, any planned evacuation may be unlikely. This is consistent with the fact that there have been no large scale efforts at evacuation from communities bordering the rivers at the time of the major floods over the last few decades, despite the catastrophic nature of these floods. The 1992 floods, in which more than 2000 people died and 2 million were made homeless, had been tracked for over a week as part of that year's monsoon. When the rains began, river levels rose and embankments were breached, flooding thousands of villages but there was no organized evacuation.²¹⁰ Similarly, the May 1999 cyclone, which affected 600,000 people in over 5000 villages on Pakistan's coast, killing almost 200 people and with several hundred persons missing and presumed dead, was followed as it approached landfall but there were no organized evacuations.²¹¹

X: Radiation doses and health effects from an accident

The radiation dose received by the population from an accident at Chashma would be from direct inhalation of the radioactive aerosol, cloudshine and ground contamination. These can be estimated separately. While each organ in each person would be exposed separately the radiation doses can be usefully summed to give whole-body doses and these doses can be further summed for the total exposed population. This simplifies the task of calculating the large scale consequences of the radiation exposure.

²⁰⁸ Federal Bureau of Statistics, *Fifty Years of Pakistan in Statistics*, Vol.3, Government of Pakistan, Islamabad, 1997, p.9.

²⁰⁹ John D. Boice Jr., *Risk estimates for radiation exposures*, in *Health Effects of Exposure to Low Level Ionizing Radiation*, Ed. W. R. Hendee and F. M. Edwards, Institute of Physics, Bristol, 1996, pp. 237-268.

²¹⁰ S. Herath, and B. Bhatti, *Pakistan floods September 1992*, International Center for Disaster-mitigation Engineering, University of Tokyo, Newsletter, vol. 1, no. 2, July-September, 1992.

²¹¹ *Pakistan: Cyclone - May 1999*, United Nations Office for the Coordination of Humanitarian Affairs, (OCHA), reliefweb, <http://www.notes.reliefweb.int/>.

The total population whole-body dose due to inhalation integrated out to a maximum distance R is:²¹²

$$D_{inh} = \frac{pQbF_{dc}^{(i)}}{v_d + \lambda_d H} \left[1 - e^{-(\lambda_f + \frac{\lambda_d}{u})R} \right]$$

where p is average population density, b is the breathing rate in m^3/s , and $F_{dc}^{(i)}$ are the inhalation dose conversion factors taken separately for whole body, lungs and thyroid doses. λ_f is Hv_d/u . The dose, D_{inh} , is in units of person-rem. The person-rem is a unit of population radiation exposure that combines the population exposed with the biological effectiveness of the absorbed dose of radiation -- in rems.²¹³

As mentioned earlier, the average population density out to a distance R of 300 km from the site has been taken as 500 persons/sq. km.

The breathing rate b is taken to be $2.3 \times 10^{-4} m^3/s$. This is the value used in the APS study. While estimates for breathing rates have changed since that study, the breathing rate for adults engaged in light activity is now given as $3.3 \times 10^{-4} m^3/s$ ²¹⁴, the average breathing rate for children is only about $1.4 \times 10^{-4} m^3/s$, [taking an average of $1.1 \times 10^{-4} m^3/s$ for children from 1 to 9 years of age, and $2 \times 10^{-4} m^3/s$ for children between 10-18 years old].²¹⁵ Since in Pakistan about half the people are less than 18 years old, an average breathing rate for the total population would seem to be about $2.3 \times 10^{-4} m^3/s$.

The radiation exposures are converted to radiation doses using dose conversion factors $F_{dc}^{(i)}$ from the 1995 guidelines of the International Commission on Radiological Protection (ICRP) -- the values are given in Appendix 6.²¹⁶ It has been assumed, as is usual, that the aerosol particles are typically 1 micrometer in diameter -- i.e. that the activity median aerodynamic diameter is 1 micrometer, and that uptake of these particles by the body is fast (classified as type F).²¹⁷

The external radiation doses experienced by people would result from being immersed in the cloud of radioactivity as it passes and from the contamination it deposits on the ground. The cloudshine dose (in person-rem) from each isotope in the cloud integrated out to a distance R is given by

$$D_{ex}^{cloud} = \frac{pQC_{ex}f_s}{v_d + \lambda_d H} \left[1 - e^{-(\lambda_f + \frac{\lambda_d}{u})R} \right]$$

²¹² Report to the American Physical Society by the study group on light water reactor safety, Reviews of Modern Physics, Vol. 47, Supplement No. 1, 1975, eq. A-II-18, p.S97.

²¹³ The rem is a unit of radiation dose, a typical natural background dose is on the order of 100 millirem/year -- a millirem is a thousandth of a rem. See for instance J. Shapiro, *Radiation protection: a guide for scientists and physicians*, Harvard University Press, Cambridge, 1990.

²¹⁴ S. Fetter and F. von Hippel, *The hazards posed by depleted uranium munitions*, (Draft), 2 July 1999.

²¹⁵ Report to the American Physical Society by the study group on light water reactor safety, Reviews of Modern Physics, Vol. 47, Supplement No. 1, 1975, Table XXXVI. p. S99.

²¹⁶ International Commission on Radiological Protection, *Age-dependent Doses to Members of the Public from Intake of Radionuclides: Part 4 Inhalation Coefficients*, Annals of ICRP Vol. 25, Nos. 3-4, 1995.

²¹⁷ G. M. Kendall, B. W. Kennedy, N. Adams, and T. P. Fell, *Effective dose per unit intake of radionuclides by adults and young people*, Radiation Protection Dosimetry, vol. 16, no. 4, pp. 307-312.

where C_{ex} are dose conversion coefficients obtained from the Federal Guidance Reports of the United States Environmental Protection Agency (EPA).²¹⁸ f_s is the shielding factor that allows for the fact that the population may not be directly exposed to the radiation, and following the APS study is taken as 0.33.

The immediate ground dose (1 day exposure) in person-rem from each isotope after it has been deposited on the ground is given by

$$D_g^{1d} = \frac{pQg_{ex}v_d\tau f_s}{v_d + \lambda_d H} \left[1 - e^{-(\lambda_f + \frac{\lambda_d}{u})R} \right] \left[1 - e^{-24/\tau} \right]$$

Here g_{ex} are the ground contamination dose conversion coefficients, and τ is measured in hours. The dose conversion coefficients are taken from the values given by the EPA.

The deposited radionuclide aerosol particles will be bound to the soil, although some may be re-suspended. Most of the deposited nuclides will be relatively immobile, and remain restricted to the upper 5 centimeters or so of the soil. This allows the long term ground doses (i.e. over 50 years), except for Cesium, to be calculated using the same equation, but omitting the last factor in the expression.

Calculation of the long term dose from the long-lived ¹³⁷Cs isotope requires considering the behavior of Cesium in the soil, and in particular its migration down from the surface with time. The rate at which this movement occurs can vary significantly, depending on soil type, acidity, rainfall, and agricultural practices, and can take place at rates of a few millimeters per year to over a cm a year.²¹⁹ This burial adds to the reduction in the dose at the surface with time after the initial contamination with cesium. Following APS this burial can be roughly described as an exponential functional of time.

The long term ground dose from deposited Cesium is calculated using:²²⁰

$$11.3 \times 10^4 \frac{pQv_d F_{dc}^{(g)} f_s}{(v_d + \lambda_d H)} \left[1 - e^{-(\lambda_f + \frac{\lambda_d}{u})R} \right]$$

The factor 11.3×10^4 results from the time integration of an empirical double exponential time-decay function for Cs. $F_{dc}^{(g)}$ are the respective dose coefficients for exposure to radioactivity deposited on the ground and are taken from US Environmental Protection Agency guidelines and are given in Appendix 5.²²¹

²¹⁸ *External exposure to radionuclides in air, water and soil*, United States Environmental Protection Agency, Federal Guidance Report No. 12, September 1993.

²¹⁹ *Chernobyl 10 Years On: Radiological and Health Impact - An Assessment* by the NEA Committee on Radiation Protection and Public Health, OECD Nuclear Agency, November 1995, <http://www.nea.fr/html/rp/chernobyl/allchernobyl.html#chap2>.

²²⁰ This follows the long term dose from ground contamination as calculated in the APS Study. The value of the integral of eq. AII.23, p. S103 is 12.88. Expressed in hours, it is 11.3×10^4 .

²²¹ *External exposure to radionuclides in air, water and soil*, United States Environmental Protection Agency, Federal Guidance Report No. 12, 1993.

The dose coefficient is taken as the sum of the effective dose coefficient and the skin dose coefficient given in the EPA guidelines, rather than just the effective dose coefficient, since the International Commission on Radiological Protection now includes skin in its definition of the effective dose.²²²

In all the calculations, the shielding factor f_s has been given a value of 0.33, the population density p taken as 500 persons/km² and the effects evaluated out to a distance R of 300 km.

The calculated doses (in million person-rem) for each isotope are listed in Appendix 7. The results for the total doses received by inhalation, cloudshine and ground contamination summed over all isotopes are given in Table V below. The total dose from ground contamination is almost 17 million person-rem.

Table VI: Total integrated doses up to a distance of 300 km from Chashma

| Source | Dose (million person-rem) |
|------------------------------------|------------------------------|
| whole body inhalation | 6.20 |
| inhalation (30 days) dose to lungs | 6.97 |
| cloud shine | 0.26 |
| ground contamination (1 day) | 1.74 |
| ground contamination (50 years) | 16.92 |

It is important to reiterate that these estimates are not the total doses that would result from the radionuclides released in an accident of the scale assumed here. The radionuclides would travel much further than the 300 km assumed in these calculations, and lead to radiation doses to people and contamination of the ground at these larger distances. There has also been no calculation of the radiation doses that would result from ingestion of radioactively contaminated food or water. This would be particularly serious in areas closer to the reactor site.

XI: Thyroid doses and children

The effects of radiation can be particularly significant for children. For example, in the 1930s and 1940s a large number of children were subject to radiation therapy to treat enlarged thymus glands. The incidence of thyroid cancer was 37 times greater in children who had been irradiated compared to their siblings who had no radiation treatment.²²³ In the aftermath of the Chernobyl accident, the incidence of thyroid cancer among children in the affected areas of Belarus and Ukraine was 200 times the rate prior to the accident.²²⁴ The thyroid gland, located below the

²²² *External exposure to radionuclides in air, water and soil*, United States Environmental Protection Agency, Federal Guidance Report No. 12, September 1993, page 6 – 7, and International Commission on Radiological Protection, *Age-dependent Doses to Members of the Public from Intake of Radionuclides: Part 4 Inhalation Coefficients*, Annals of ICRP Vol. 25, Nos. 3 – 4, 1995, p.4.

²²³ *Health Risks Associated with Low Doses of Radiation*, EPRI TR-104070, Electric Power Research Institute, Palo Alto, CA, 1994, p. 6-3.

²²⁴ *Chernobyl in Perspective*, IAEA Bulletin, Quarterly Journal of the International Atomic Energy Agency, vol. 38, no. 3, 1996, p. 32.

Adam's apple in the neck, uses iodine to produce hormones that help regulate the pulse, blood pressure, body temperature and is particularly important in child development.

To estimate the incidence of thyroid cancer following an accident at Chashma, ICRP dose conversion factors and breathing rates for children have been assumed.²²⁵ The dose coefficients for five age groups (3 months, 1 year, 5 years, 10 years and 15 years) were linearly averaged to get dose coefficients for children up to the age of 15 years. The breathing rates for children were averaged to $2 \times 10^{-4} \text{ m}^3/\text{s}$ and for adults, the value of $4 \times 10^{-4} \text{ m}^3/\text{s}$. This amounts to assuming that the population was awake and engaged in what is described as light exercise.

According to the 1981 census, about 44% of Pakistan's population were under the age of 15 years.²²⁶ For the year 2000, the population of Pakistan under the age of fifteen has been projected as 41.8% of the total (with 55.0% between 15 and 56 years old, and 3.2% over the age of 65).²²⁷ A preliminary report from the 1998 census indicates that in one semi-urban district, with a total population of almost 1 million, 45% of the population is below 15 years of age.²²⁸ It is assumed for the purposes of calculation that 40% of the population is in this age group.

The estimated thyroid dose to the population due to inhalation of the passing radioactive aerosol is given in Appendix 8. Iodine isotopes are the most important contribution, but there is also a non-negligible contribution from Technetium isotopes.

The total thyroid dose to children up to 15 years of age is 140 million person-rem, while the total thyroid dose to adults (i.e. population over the age of 15 years) is 74 million person-rem.

XII: Cancer incidence

The health effects of exposure to radiation are difficult to judge accurately, as is clear from the variation among the cancer risk models that have been developed.²²⁹ However, it is widely agreed that the most significant long term effect from exposure to low doses of radiation will be an increase in the risk of cancer among those exposed. This risk is highly variable; for instance, the risk to children is about twice that for adults. The number of people who would get cancer following a radiation dose may be significantly higher than those who die; the number depends on the particular organ that becomes cancerous and the proportion of such cancers that can usually be successfully treated. The fraction of cancers at a particular site that are fatal varies

²²⁵ International Commission on Radiological Protection, *Annals of the ICRP Vol. 25, Nos. 3-4, 1995: Age-dependent Doses to Members of the Public from Intake of Radionuclides: Part 4; Inhalation dose coefficients.*

²²⁶ Federal Bureau of Statistics, *50 years of Pakistan in Statistics*, vol. III, Government of Pakistan, Islamabad, 1997, Population by age, sex, urban/rural areas, 1981 census, Table 2.6, p. 9.

²²⁷ *World Resources 1998-1999: A Guide to the Global Environment*, World Resources Institute, UNEP, UNDP, World Bank, Oxford University Press, 1998, Trends in Births, Life Expectancy, Fertility, and Age Structure, 1975-2000, Data Table 7.2, p. 247.

²²⁸ *Mirpurkhas population 905,935*, Dawn, 23 August 1999, <http://www.dawn.com/daily/19990823/local15.htm>.

²²⁹ See for instance, *Estimating radiogenic cancer risks*, United States Environmental Protection Agency, EPA 402--93-076, Washington DC, 1994.

from 99% lethality for acute leukemia, 95% for lung cancer, 50% for breast cancer and 10% for thyroid cancer.²³⁰

There are also problems in transferring the estimated risk of cancer based on a study of one population to determining the risk to another different population, especially since the background incidence of cancer and the rate of particular kinds of cancers vary between populations. The mortality rates from radiation exposure for most ordinary people in a third world country may be higher than for people in developed countries simply because the quality of medical treatment may not be as high, or care may too expensive for them to afford or simply not available. Poverty and the long term effects of poor nutrition may further increase the risk. About 20% of Pakistan's urban population and 30% of its rural population (which makes up about 60% of the total population) are classed as poor on the basis of not being able to meet the Recommended Daily Allowance of calories for adults (2,550 calories).²³¹ At the same time, the poor having lower life expectancies may die from other causes before they contract cancer or die from it. None of these effects are included in the estimates given below.

In 1990 the US National Research Council's Committee on the Biological Effects of Ionizing Radiation (known as BEIR V) considered the possible rate of cancer deaths from radiation exposure for the US population. Following a single exposure equivalent to 10 rem it was estimated about 800 people would die per 100,000 people exposed (i.e. 800 deaths per million person-rem), while for an exposure of 0.1 rem/year for a lifetime (as would be the case for example from ground contamination) it would be about 550 deaths.²³² A more recent US Environmental Protection Agency estimate is that the rate could be 972 fatal cancers per million person-rem, while at low doses and low dose rates this could be 509 deaths.²³³ These fatalities are a fraction of the significantly larger number of people who would get cancer. It has been estimated that for the US population about 70% of all cancers induced by whole body irradiation may be non-fatal.²³⁴

Despite the limitations of transferring such cancer risk models, which depend on the specific age distribution of the population, the rate of death from different causes, and cancer mortality rates, these models make it possible to get at least a preliminary estimate of the cancer deaths that may result from the whole body exposures following an accident at Chashma.

The calculations of the radiation doses received following a hypothetical accident at Chashma suggested:

1. Total thyroid dose to children up to 15 years of 140 million person-rem
2. Total thyroid dose to adults of 73 million person-rem
3. Total whole body inhalation dose of 6.2 million person-rem
4. Total lung inhalation (30 days) dose of 6.97 million person-rem
5. Total dose from cloudshine of 0.26 million person-rem

²³⁰ See for instance, *Estimating radiogenic cancer risks*, United States Environmental Protection Agency, EPA 402--93-076, Washington DC, 1994, table 5, p. 27.

²³¹ *Just Development: Beyond Adjustment with a Human Face*, eds. T. Banuri, S. R. Khan, and M. Mahmood, Oxford University Press, Karachi, 1997, P. 70.

²³² National Research Council Committee on the Biological Effects of Ionizing Radiation, *Health effects of exposure to low levels of ionizing radiation - BEIR V*, National Academy Press, Washington DC, 1990, p. 172.

²³³ *Estimating radiogenic cancer risks*, United States Environmental Protection Agency, EPA 402--93-076, Washington DC, 1994, table 5, p. 26, 30.

²³⁴ *Estimating radiogenic cancer risks*, United States Environmental Protection Agency, EPA 402--93-076, Washington DC, 1994, table 5, p. 29.

6. Total dose from ground contamination (1 day) of 1.74 million person-rem
Total long term dose from ground contamination is 16.92 million person-rem

The total long term whole body radiation dose is simply the sum of the whole body inhalation dose (6.2 million person-rem), the cloudshine dose (0.26 million person-rem) and the long-term ground dose (16.92 million person-rem), in other words 23.38 million person-rem. Using the values for the number of deaths per million person-rem cited above would imply roughly between 12,000- 23,000 cancer deaths from the whole body dose. This would imply that the number of cancer deaths arrived at above may be only one-third of the total cancer cases, which would be of the order of 36,000-69,000.

The incidence of thyroid cancer following inhalation of the radioactive aerosol by children (below about 15 years of age) can be estimated assuming that the risk of development of thyroid cancer during a person's life after exposure (taken here to last 50 years after the exposure) is 125 per million person-rem.²³⁵ For the total thyroid dose to children of 140 million person-rem calculated earlier, this would suggest that there may be 17,500 cases of thyroid cancer. It is normally assumed that 10% of the malignant thyroid cancers may eventually be fatal, which would suggest there may be over 1700 deaths.

These cases will begin to appear typically after the children have passed through puberty, and female children may be two or three times more susceptible than males to this cancer.²³⁶ As mentioned earlier, the incidence of thyroid cancer among children in the areas of Belarus and Ukraine affected by radiation from Chernobyl was 200 times the rate prior to the accident.²³⁷ By 1995, there were more than 800 diagnosed cases of child thyroid cancer mainly in Belarus.²³⁸ It has been suggested that as many as 10% of the young children in the areas most exposed by Chernobyl may eventually contract thyroid cancer.²³⁹

For adults (greater than about 15 years of age), the risk of thyroid cancer can be taken to be about 25 per million person-rem.²⁴⁰ This would suggest that for a dose of 73 million person-rem there would be about 1800 cases of thyroid cancer, of which almost 180 would be fatal.

These estimates may be very conservative. It has been proposed that the risk of thyroid cancer could be significantly higher, ranging from 100-600 thyroid cancers per million person-rem -- of which one-quarter would be malignant.²⁴¹ If this were to be the case, the incidence of thyroid

²³⁵ National Research Council Committee on the Biological Effects of Ionizing Radiation, *Health effects of exposure to low levels of ionizing radiation - BEIR V*, National Academy Press, Washington DC, 1990, p.294.

²³⁶ National Research Council Committee on the Biological Effects of Ionizing Radiation, *Health effects of exposure to low levels of ionizing radiation - BEIR V*, National Academy Press, Washington DC, 1990, p.284.

²³⁷ *Chernobyl in Perspective*, IAEA Bulletin, Quarterly Journal of the International Atomic Energy Agency, vol. 38, no. 3, 1996, p. 32.

²³⁸ *Chernobyl Ten Years On - Radiological and Health Impact: An Assessment by the NEA Committee on Radiation Protection and Public Health*, November 1995, OECD Nuclear Energy Agency <http://www.nea.fr/html/rp/chernobyl/c03.html>.

²³⁹ *Chernobyl's thyroid cancer toll*, Science Vol. 270. 15 December, 1995, p 1758-9.

²⁴⁰ National Research Council Committee on the Biological Effects of Ionizing Radiation, *Health effects of exposure to low levels of ionizing radiation - BEIR V*, National Academy Press, Washington DC, 1990, p.293.

²⁴¹ F. von Hippel and T. Cochran, *Chernobyl, the emerging story: estimating the long term health effects*, Bulletin of the Atomic Scientists, August/September 1986, pp. 18-24.

cancer among children could be as high as 84,000 cases, with 21,000 being malignant, and leading to as many as 8,400 deaths. For adults, there could be as many as 11,000 malignant thyroid cancers and possibly over 1,000 deaths.

Even this value may underestimate somewhat the consequences. There have been suggestions that widespread iodine deficiency among children in Belarus may have contributed to the high incidence of thyroid cancer following the Chernobyl accident.²⁴² There is widespread iodine deficiency in Pakistan, with perhaps 65 million people (half the population) affected by iodine deficiency disorder.²⁴³ This includes a large proportion, perhaps a half, of all children.²⁴⁴

The radiation dose to the lungs from inhalation has been estimated to lead to about 72 deaths per million person-rem.²⁴⁵ For Chashma, this would suggest about 500 deaths from lung cancer.

The results are summarized in Table VII.

Table VII : Estimated cancer deaths from radiation exposure

| | Deaths |
|--------------------|-----------------|
| whole-body | 12,000 - 23,000 |
| thyroid (children) | 1,700 - 8,400 |
| thyroid adult | 180 - 1,000 |
| lung | 500 |

For comparison, after the Chernobyl accident it was estimated there would be about 6,600 cancer deaths among the population living in the areas of Belarus, Ukraine and Russia most contaminated by the accident -- 326,000 of whom were evacuated after the accident.²⁴⁶ Other estimates suggest there may be eventually 2,000 to 40,000 thyroid tumor cases, as well as 3,500-70,000 cancer cases, of which half may be fatal, from the whole body doses produced by Cesium contamination.²⁴⁷

XIII: Environmental effects

Radioactivity deposited on the ground would make certain areas unfit for safe habitation and cultivation. In the short term, iodine poses the greatest risk for both occupation and cultivation

²⁴² M. Gembicki, A. N. Stozharov, A. N. Arinchin, K. V. Moschik, S. Petrenko, I. M. Khmara, K. F. Baverstock, *Iodine deficiency in Belarusian children as a possible factor stimulating the irradiation of the thyroid gland during the Chernobyl catastrophe*, Environmental Health Perspectives, 105, Supplement 6, December 1997, pp. 1487-1490.

²⁴³ Richard Galpin, *millions at risk from iodine deficiency*, BBC News, 1 December, 1999, <http://news2.thls.bbc.co.uk/hi/english/health/newsid%5f225000/225557.stm>.

²⁴⁴ *50% children in Northern Areas, Punjab, iodine deficient*, Dawn, 20 November 1999.

²⁴⁵ *Estimating radiogenic cancer risks*, United States Environmental Protection Agency, EPA 402--93-076, Washington DC, 1994, p. 30.

²⁴⁶ *Chernobyl in Perspective*, IAEA Bulletin, Quarterly Journal of the International Atomic Energy Agency, vol. 38, no. 3, 1996, p. 18-19.

²⁴⁷ F. von Hippel and T. Cochran, *Chernobyl, the emerging story: estimating the long term health effects*, Bulletin of the Atomic Scientists, August/September 1986, pp. 18-24.

over the largest distances and the largest areas. The long term contamination is from Cesium-137, Cesium-134 and Strontium-90.

There have been two large releases of radioactivity that led to evacuation of potentially affected populations. After the Chernobyl accident, large areas were contaminated mainly by Cesium-137 and a ground contamination level by this radionuclide of about 15 microcuries/m² was used as the criterion for temporary relocation of the population and 40 microcuries/m² as the intervention criterion for permanent resettlement of population.²⁴⁸ At Chernobyl, a 30 km exclusion zone was set up from which everyone was evacuated, and people may never be allowed to return.²⁴⁹ The second accident was the explosion of a tank containing radioactive waste from a Soviet reprocessing plant at Chelayabinsk-65 in the southern Urals (the "Kyshtym disaster") on 29 September 1957; 20 megacuries of radioactivity were released into the environment and areas contaminated with greater than 2 microcuries/m² of Strontium-90 were evacuated.²⁵⁰

The wedge model gives the ground contamination at large distances following a release of radioactivity as $\sigma(r) = v_d \chi(r)$ curies/m² for each isotope as a function of distance. This will be the contamination from the initial deposition. The dose from each isotope was calculated out to the distance at which the dose was equal to the thresholds for occupation and cultivation. The area that would be contaminated above these thresholds is the area under the wedge up to the respective distances. [For $\theta=0.25$ radian, this area is $(1/8)*R^2$].

Ground contamination from Cesium-137 will reach the level used as the criterion for permanent evacuation after Chernobyl (40 microcuries/m²) at a distance of 26 km from the reactor, and for temporary evacuation (15 microcuries/m²) at a distance of about 70 km. The ground contamination from Strontium-90 will fall below the criterion used at Chelyabinsk for evacuation (2 microcuries/m²) at a distance of 54 km. At these distances, if the direction of the wind were to be towards the northeast, Mianwali city and its surrounding areas would have to be evacuated, and the evacuation would have to extend as far as Kalabagh. If the wind were to be towards the west, the nuclear reactor at Khushab (about 80 km away) and surrounding areas might have to be evacuated. If the wind were to be towards the southwest, the city of Dera Ismail Khan and its surrounding areas would have to be evacuated.

The corresponding total areas that would need to be evacuated permanently because of long term contamination by Cesium-137 is about 85 km², and temporary resettlement would have to cover an area of 612 km². The area that would have to be evacuated because of Strontium contamination would be about 365 km².

This radioactive contamination would affect agricultural production in these areas. Certain isotopes concentrate in grass, grains, vegetables and fruits and also milk dairy product and meat. These concentrations are typically greater than are actually deposited on the ground. The population in many areas of Punjab is largely rural with people dependent on agriculture for their

²⁴⁸ *Chernobyl Ten Years On - Radiological and Health Impact: An Assessment* by the NEA Committee on Radiation Protection and Public Health, November 1995, OECD Nuclear Energy Agency
<http://www.nea.fr/html/rp/chernobyl/c03.html>.

²⁴⁹ *Chernobyl Ten Years On - Radiological and Health Impact: An Assessment* by the NEA Committee on Radiation Protection and Public Health, November 1995, OECD Nuclear Energy Agency
<http://www.nea.fr/html/rp/chernobyl/allchernobyl.html>.

²⁵⁰ T. B. Cochran, R.S. Norris, and O.A. Bukharin, *Making the Russian bomb: from Stalin to Yeltsin*, Westview Press, Boulder, 1995, p. 109-113.

livelihood. The loss of agricultural land would mean large scale long term displacement of these people.

XIV: Effects on the irrigation and groundwater system

The Chashma reactor is close to the river Indus. The reactor is described as drawing its cooling water from Chashma-Jhelum Link Canal. Under normal circumstances most of the water in the Chashma Barrage reservoir would flow through Chashma Barrage and continue down the Indus, and a small fraction would be diverted into the Chashma-Jhelum Link Canal, which connects the Indus River to the Jhelum River, and into another much smaller, older canal, the Paharpur, which also takes water from the Barrage to irrigate land to the west of the Indus. The Barrage is designed to have a maximum discharge of 848 billion m³ per year, while the Chashma-Jhelum Link Canal is described as a 100 km long, 4m deep and 100m wide, unlined canal.²⁵¹

Chashma Barrage has created a reservoir on the Indus, with a surface area of 356 square kilometers.²⁵² This large water body is a few kilometers north from Chashma Nuclear Power Plant. In the event of the radioactive plume from Chashma passing over this reservoir its surface will receive the fall out. From satellite pictures, we assume that the reservoir is about 30 km long and 12 km wide and for the purposes of calculation assume that the distance between the reactor and the lake is 10 km. The reactor is actually closer, perhaps only 3 km from the Barrage.

Within the wedge model of atmospheric dispersion, the amount of radioactivity falling on the surface under the wedge from a distance r_i to r_f is given by:

$$\sigma = \frac{Q \cdot v_d}{v_d + \lambda_d H} \cdot \left[e^{-\lambda r_i} - e^{-\lambda r_f} \right] \text{ curies}$$

where

$$\lambda = \frac{1}{u} \left(\frac{v_d}{H} + \frac{\ln 2}{\tau} \right)$$

The amount of radioactivity from each of the isotopes falling on the water surface is given in Appendix 9. The total deposition on the water body is estimated to be 2.82 megacuries. If the reactor is closer to the lake, the deposition on it may be greater; however the wedge model may not be particularly suitable for making a reliable estimate at distances this close to the reactor.

The deposition of radioactivity from an atmospheric plume onto a water body and its subsequent settling as sediments were observed at Chernobyl. The accident led to almost 0.2 megacuries of radioactivity being deposited onto the 22 km² surface of the cooling water reservoir serving the reactor; the distribution of some of these deposited isotopes is shown in Table VII below.²⁵³

²⁵¹ N. Ahmad, *Water Resources of Pakistan and their Utilization*, Shazad Nazir, Lahore, 1993, p.4.34.

²⁵² F. W. Kruger: *Adapting planning to conditions in developing countries*; Nuclear Engineering International, May 1993, pp. 25-27.

²⁵³ United Nations Scientific Committee on the Effects of Atomic Radiation (UNSCEAR) 1996 Report to the General Assembly, *Sources and Effects of Ionizing Radiation*, United Nations, New York, 1996, Table 21, p. 71.

Table VII: Estimated distribution of some radionuclides following deposition onto the cooling pond at Chernobyl

| | activity in sediment (curies) | activity in water (curies) |
|-----------|----------------------------------|-------------------------------|
| Cesium | 2970 (\pm 1300) | 1620 (\pm 810) |
| Iodine | 810 (\pm 270) | 6750 (\pm 1620) |
| Strontium | 1350 (\pm 540) | 162 (\pm 108) |

The deposition onto water near the site created significant problems at Chernobyl.²⁵⁴ To prevent the contaminated water from this cooling pond getting into the nearby river through the groundwater, a 30 meter wall was built into the ground. To stop the spread downstream of radioactive sediments, formed directly on the rivers from radionuclide deposition, underwater dams with a deep groove in front of them were constructed across the rivers. In one case the dam was 450 m long while the groove was 100 m wide and 16 m deep. It was these and other emergency measures which took months, and in some cases years to construct, and required some 800,000 workers. These emergency workers, half of whom were from the Soviet armed forces, became known as "liquidators." They were all exposed to radiation, but there is little reliable data on the exposures.²⁵⁵

In the event of an accident at Chashma depositing radioactivity onto the lake behind the Barrage, the water could feasibly be prevented from continuing down the Indus. Chashma Barrage has electrically operated gates in its sluices. However, this would soon lead to flooding as the Indus water level increased above the Barrage height, or simply went around the Barrage. Flooding would re-suspend sediments and deliver them to the land surface, where they would add to the contamination produced by deposition from the cloud. Measurements of ground contamination in the Netherlands after the Chernobyl accident show clearly that in areas that are prone to flooding the activity of Cesium more than doubled after water containing radioactive sediments inundated the area.²⁵⁶

In the case of Chashma, contaminated water would in any case continue to pass into the canals which siphon off water before it reaches the Barrage gates. There would presumably be deposition of radioactivity from the water onto the base and walls of the canals. The absence of a lining to the canals increases the rate at which radioactivity would be able to migrate through the canal base and walls and into the groundwater, which is close the surface.

It is not just surface water that would be contaminated. The Chashma containment building has an internal diameter of 36 m, a thickness of 1 m and a total height of 60 m and it is lined with a 6 mm steel liner. The reactor pressure vessel rests on a 5.65 m thick concrete foundation mat.²⁵⁷ In the event of a core meltdown the molten fuel, at temperatures possibly in excess of 2000 K, will attack the concrete and sink into and pass through it. Studies suggest that a molten reactor core will reach thermal equilibrium with the surrounding soil once it has penetrated no more than

²⁵⁴ D.R. Marples, *The social impact of the Chernobyl disaster*, St. Martin's Press, New York, 1988, pp. 59-87.

²⁵⁵ *Chernobyl Ten Years On - Radiological and Health Impact: An Assessment by the NEA Committee on Radiation Protection and Public Health*, November 1995, OECD Nuclear Energy Agency <http://www.nea.fr/html/rp/chernobyl/allchernobyl.html>.

²⁵⁶ Coordinating Committee for Monitoring of Radioactive and Xenobiotic Substances (CCR), *Report on the post-Chernobyl supplementary monitoring programme*, Ministry of Housing, Physical Planning and Environment, The Hague, April 1989, p. 27, Table 6.3.1.

²⁵⁷ Mirza Azfar Beg and Saeed A. Siddiqi, *Chashma Nuclear power project*, Dawn, 21 November 1995

perhaps 3 m, and that the radionuclides would then migrate at about 3 m per year through the earth.²⁵⁸

At Chashma, even if the molten core solidifies at a depth of 3 m it could reach the watertable, since the groundwater may be at most a few meters below the foundations of the reactor. If the water table is presently more than 3 m below the concrete mat that serves as the reactor's foundation it may not remain so for the lifetime of the reactor. The water table has been rising in many areas of Pakistan, in part because up to 50% of the water in the mostly unlined canals is lost as seepage into the ground.²⁵⁹ Once in the groundwater, the radionuclides may travel faster than 3 m/year. Recent measurements at the site suggest the ground water velocity may about 5 cm/day or about 18 m/year.²⁶⁰

At Chernobyl, it has been estimated that leaching from the remaining fuel mass may become larger with time, and that Strontium-90 may contaminate drinking water in the area for the next 10-100 years.²⁶¹

It is not just soluble radionuclides that may be mobilized and transported large distances underground. A study of the Nevada nuclear weapons test site has identified submicrometer sized plutonium colloid particles that had been produced during and after a 1968 underground nuclear test and subsequently transported by groundwater at a rate of 42 m/year, over a distance of 1.3 km.²⁶² Other radionuclides that form such colloids include Cesium and Strontium.

These rates of movement of radioactive contamination through the ground and groundwater assume that the speed is limited by the bulk properties of the soil. The presence of a major fault close to the reactor and possibly directly beneath it could increase the rate of transport of any contaminated groundwater. A fault may act as a vertical channel of high permeability that would allow contaminants to reach deep underground and may also allow contaminants to move large horizontal distances. If the radionuclides reached the fault identified as lying close to Chashma then they may be able to affect ground water as far as 100 km away from the site.

XV: Conclusions

The Chashma nuclear power plant is scheduled to begin operating in spring of 2000. There has been no public environmental impact assessment of the project, despite the legal requirement imposed by Pakistan's 1983 Environmental Protection Ordinance and the subsequent Environmental Protection Act of 1997.

The limited available information about the Chashma site suggests that there are reasons for concern about its suitability as a location for a nuclear reactor. An independent study of the

²⁵⁸ Report to the American Physical Society of the study group on radionuclide release from Severe Accidents at Nuclear power Plants, (Draft) February 1985, p. 91.

²⁵⁹ H. Bender, *Water*, in *Geology of Pakistan*, eds. F.K. Bender and H.A. Raza, Gebruder Borntraeger, Berlin, 1995, p. 309.

²⁶⁰ S.D. Hussain, M. Ahmed, M. Rafiq, and N. Ahmed, *Measurement of Groundwater flow velocity at CHSNUPP site using radiotracer technique*, PINSCTECH/RIAD-125, Pakistan Institute of Nuclear Science and Technology, Islamabad, 1991.

²⁶¹ *Chernobyl Ten Years On - Radiological and Health Impact: An Assessment by the NEA Committee on Radiation Protection and Public Health*, November 1995, OECD Nuclear Energy Agency <http://www.nea.fr/html/rp/chernobyl/allchernobyl.html>.

²⁶² A. B. Kersting, D. W. Efurud, D. L. Finnegan, D. J. Rokop, D. K. Smith, J. L. Thompson, *Migration of plutonium in ground water at the Nevada Test Site*, *Nature*, vol. 397, 7 January, 1999.

seismology and geology of the Chashma prepared for PAEC identified the seismic risk at the site to be "severe", and suggested that there was a possibility of a very large earthquake on a fault within 10 km, and possibly even closer, of the site.

Located on the banks of the Indus, the reactor is not build on hard rock foundations but on a concrete raft that sits in the sand deposited over the years by the river. The soft and wet sand raises the further danger that even moderate sized earthquakes may generate liquefaction, significantly increasing the ground motions. An additional factor may be a local increase in the severity of these motions by the presence of water in the sediments.

All of the above factors would appear to violate the guidelines for siting nuclear power plants currently in use in the United States.

There may be problems with the design of Chashma also. The initial Chashma design was based on a Chinese prototype that was in turn based on adaptation of an earlier, possibly incomplete, Westinghouse reactor design. Problems with this initial Chashma design are suggested by the changes made in it by PAEC and the further changes recommended by the IAEA. There may have been disputes over the former changes, and it appears not all of the latter recommendations were adopted. Through these processes, the design may have evolved into a hybrid that is not as safe as it could be.

The accident in 1998 at the Chinese prototype reactor for Chashma showed that there may be significant limitations in its design and that the Chinese nuclear industry were unable to deal with problems at their own reactor. The Western company called in to do the repairs had to redesign components that were found to have been too weak to withstand the normal operation of the plant. Such assistance would not be available to Pakistan.

The components used in Chashma may have reliability problems. China relied on imported components for Qinshan-1, including those most critical for reactor safety such as the pressure vessel, primary coolant pumps and the control system. For Chashma all these components were the first of their kind to be manufactured by China. International nuclear industry sources have questioned China's capability to manufacture these components to the exacting quality standards required for safety and reliability and there is evidence that China had problems. These doubts may explain why China continues to rely on importing nuclear power plants and their components. It is noteworthy that, citing the high cost of nuclear electricity, China has recently announced its nuclear power plans have been frozen for the next several years.²⁶³

PAEC has a history of difficulties with reliably and safely operating a nuclear power plant. KANUPP, Pakistan's only working nuclear power plant, is among the worst performing nuclear power plants in the world. The fact that it is kept operating despite its poor performance, its age and other problems, suggests a willingness to take risks with safety on the part of PAEC.

An accident at Chashma that led to a meltdown of the core would release large amounts of radiation to the environment. A simple model of the consequences suggests that in the long term over distances of about 300 km there may be 12,000-23,000 cancer deaths, and perhaps three times as many cases of cancer. There may over 8,000 deaths from thyroid cancer following the exposure of children to the radiation released, and 1,000 deaths among exposed adults.

²⁶³ *Nuclear programme: China shelve plans for more nuclear plants*, Power Economics, 25 June, 1999.

Some countries have responded to the concerns this raises about the possible effects of future reactor accidents involving the release of radioactive iodine by introducing precautionary measures. One measure is to provide potassium iodide tablets, which saturates the thyroid gland with a stable isotope of iodine and so prevents the uptake of any radioactive iodine that may have been released from a reactor accident. In Poland, 10.5 million children and 7 million adults were given potassium iodide after the Chernobyl accident. Britain has subsequently decided to stock potassium iodide in schools, police stations and other locations near nuclear power plants, while France has a program of distributing potassium iodide tablets to people living within a distance of 10 km from 24 nuclear installations – including its 20 nuclear power plants. The World Health Organization has recommended that all school children in Europe have immediate access to potassium iodide in the event of a nuclear accident, irrespective of distance from a nuclear facility.²⁶⁴ Pakistan should consider similar measures.

Significant areas extending to 70 km from the nuclear power plant would have to be evacuated in case of an accident because of the high levels of contamination. Surface and groundwater could be contaminated perhaps to distances of 100 km.

It would appear therefore that Pakistan risks a possible environmental and public health catastrophe with the Chashma nuclear power plant. The limited public information on the location, the reactor design, the reliability of the components, and the implications of the design failures revealed by the Qinshan-1 accident suggest that the Chashma reactor should not be permitted to begin operating until there has been a full independent, expert review and environmental impact assessment of the project.

²⁶⁴ *France distributes iodine near reactors*, Science Vol. 275 28 March, 1997, p 1871-2

Map 1 : Possible sites for nuclear power plants identified by PAEC in the 1975 Nuclear Power Planning Study

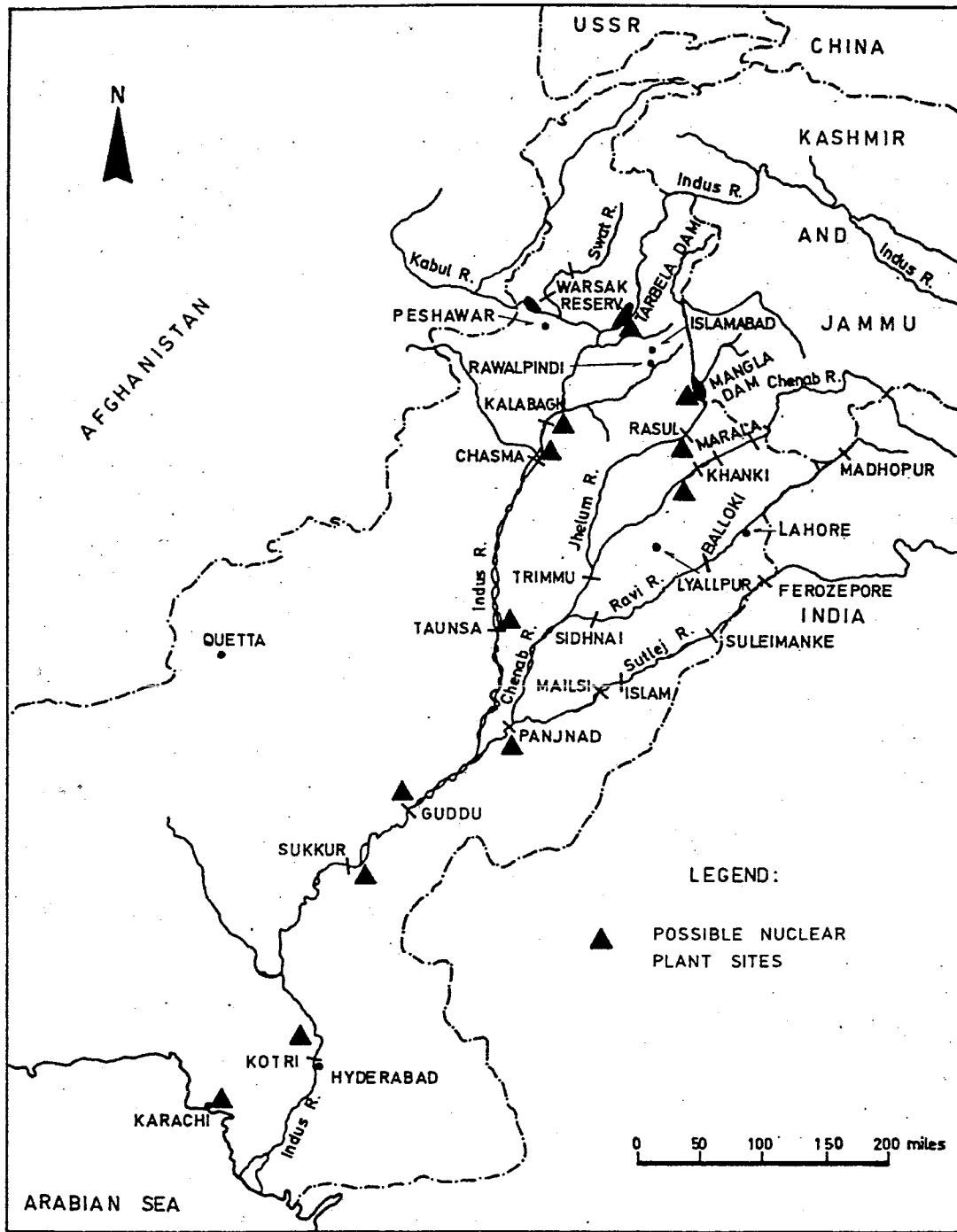

Source: Nuclear Power Planning Study for Pakistan, International Atomic Energy Agency, Vienna, 1975, p. 23.

Map 3 : The Chashma site and its surroundings

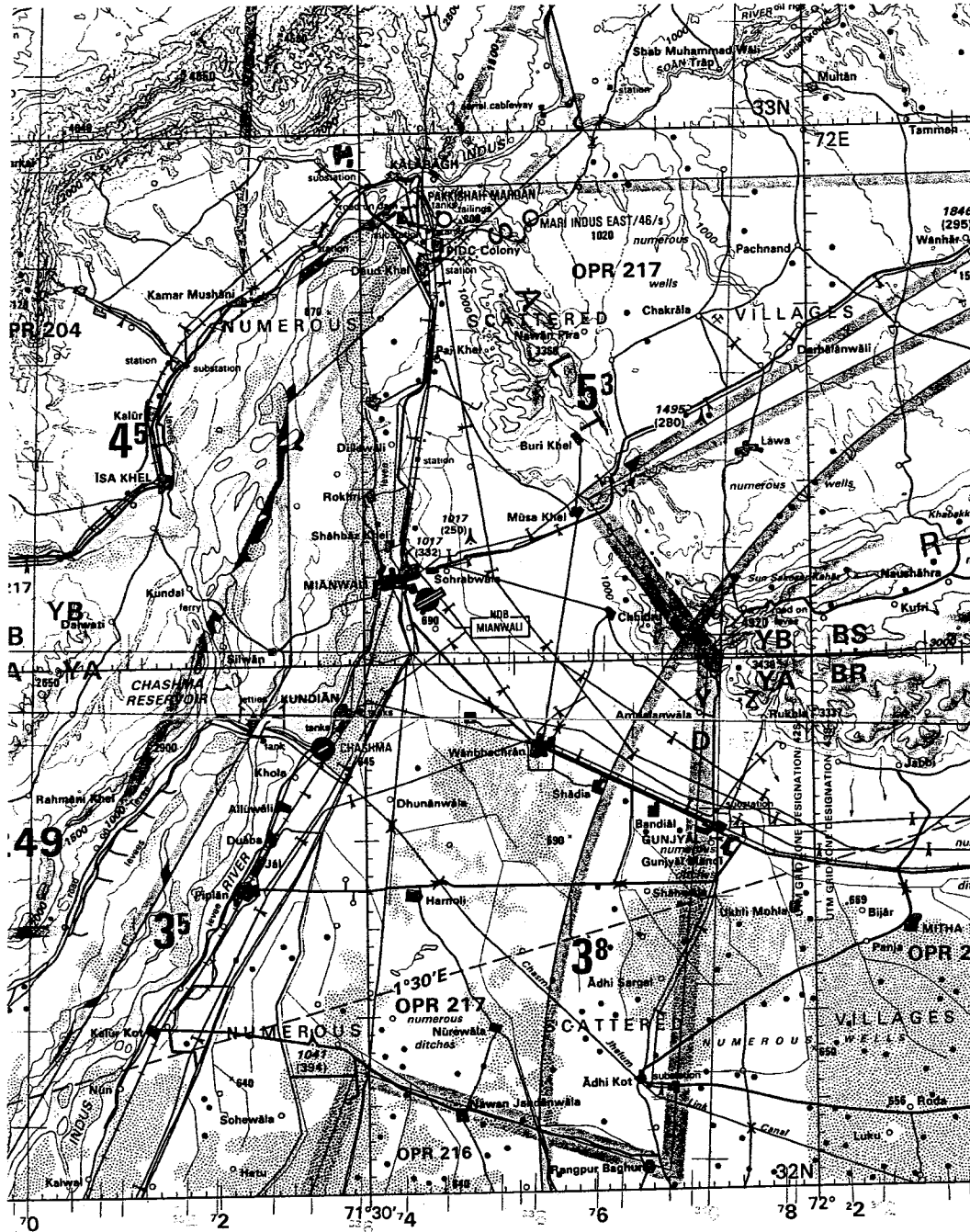

The resolution is 1: 500,000 (1 cm is equal to 5 km)

Source: US National Imagery and Mapping Agency, Tactical Pilotage Chart TPC-G-6C, edition 3, 1992.

Map 4 : The epicenters of earthquakes within Pakistan recorded between 1905-1972 and the inferred active faults

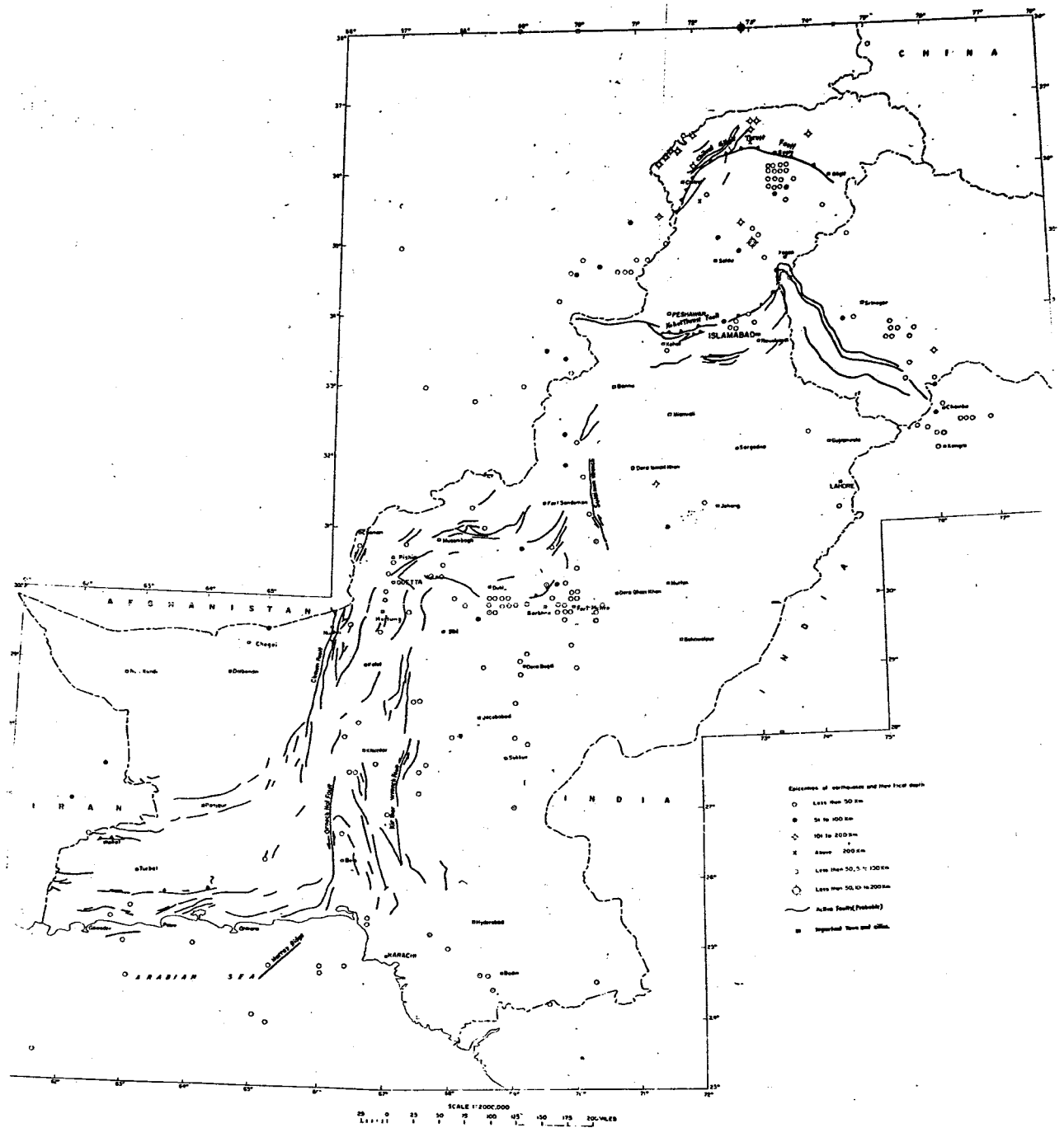

Source: M. A. Ahmad, Earthquake maps of Pakistan, Geological Survey of Pakistan, Quetta, 1974.

Map 5 : Active faults and lineaments in Pakistan inferred from aerial photographs, Landsat images and seismological data

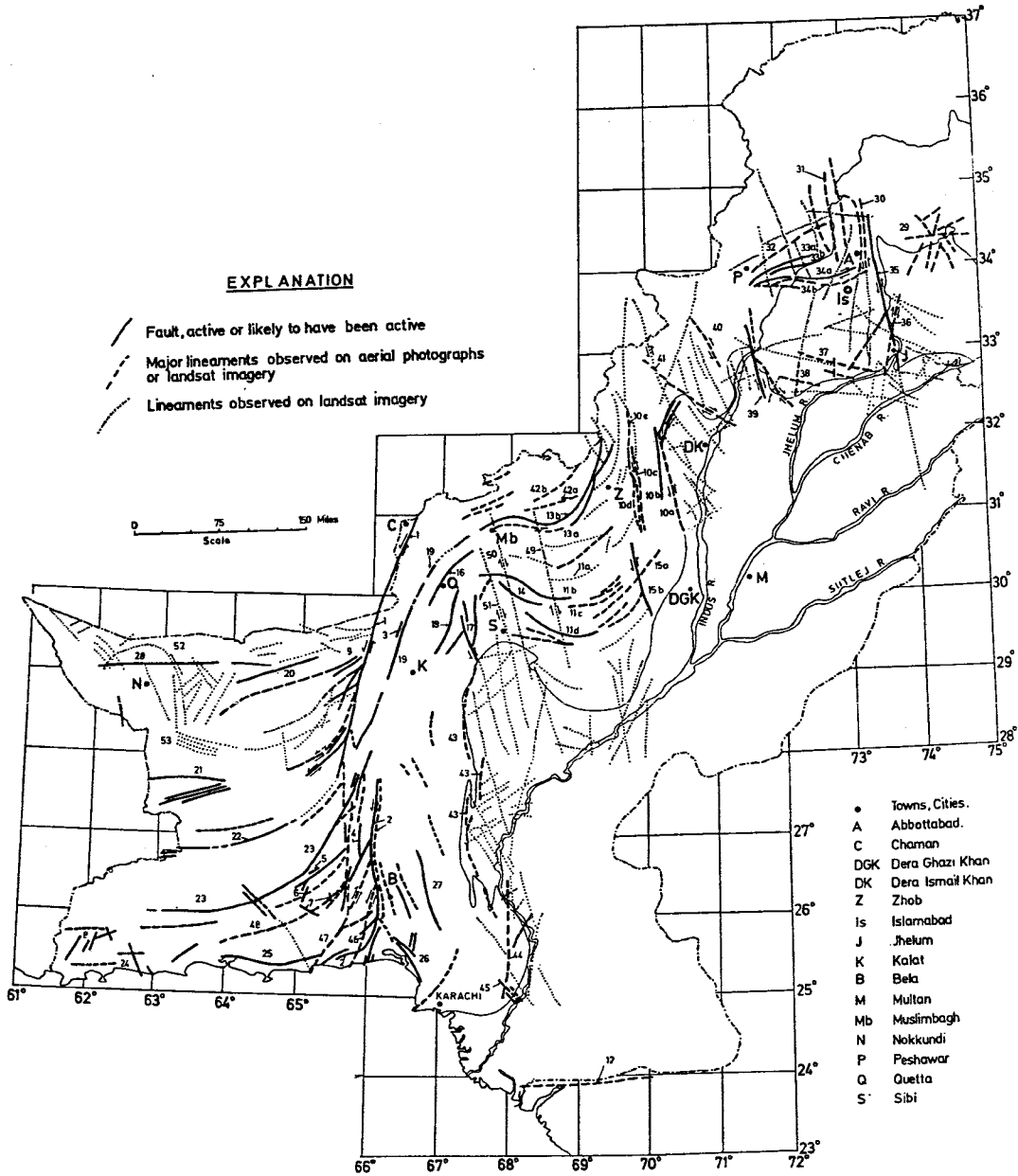

Lineaments may represent the surface expression of deep-seated fractures and faults.

Source : A.H. Kazmi, Active fault systems of Pakistan, in Geodynamics of Pakistan, A. Farah and K. A. DeJong, editors, Geological Survey of Pakistan, Quetta, 1979, p. 286.

Map 6 : Earthquake epicenters from the Tarbela dam seismic network 1974-1975

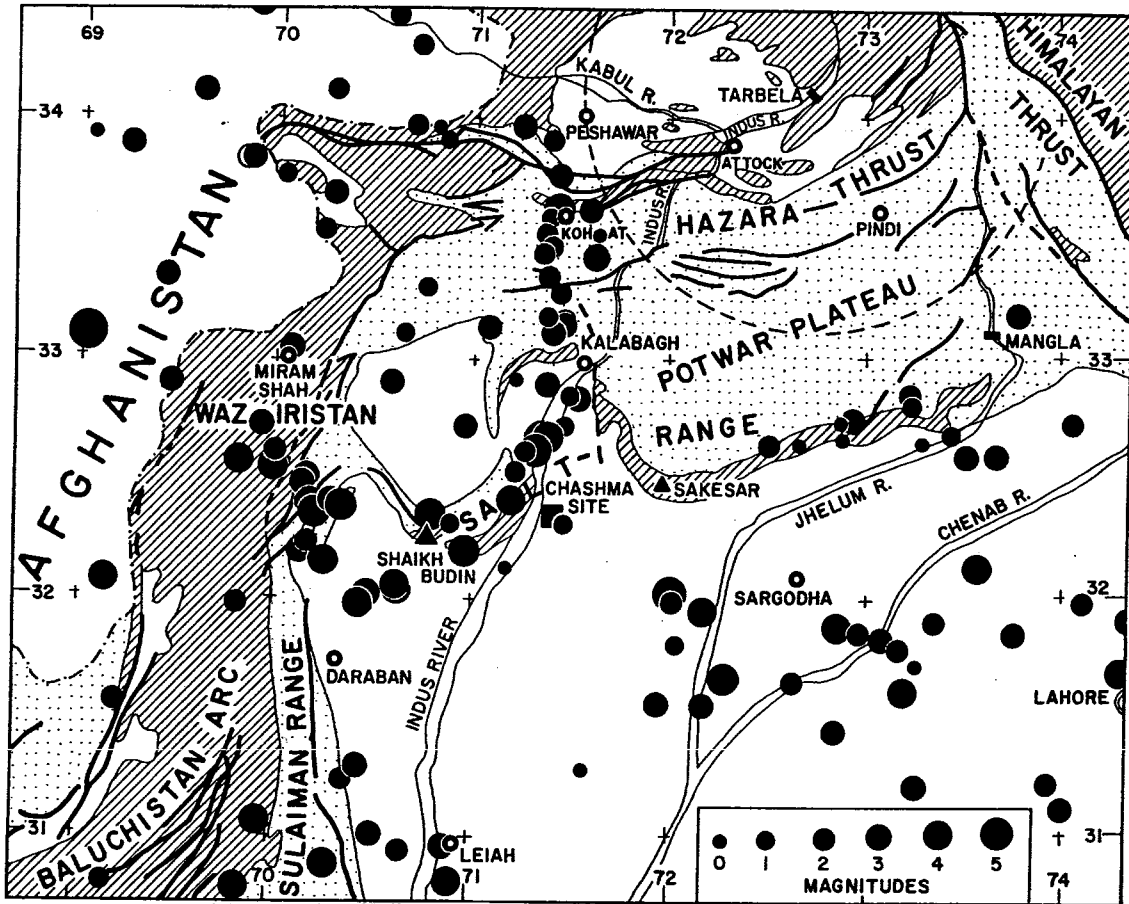

Earthquake locations and magnitudes recorded by the Tarbela Dam seismic network between June 1974 and July 1975 at distances greater than 100 km from Tarbela (marked by the large circle).

Source: L. Seeber, J. Armbruster, K. H. Jacob, Seismotectonic study in the vicinity of the Chashma nuclear power plant site, Pakistan, Report No. 3, Lamont-Doherty Geological Observatory of Columbia University, April 1977, figure 7.

Map 7 : Earthquake epicenters from the Chashma and Tarbela seismic networks

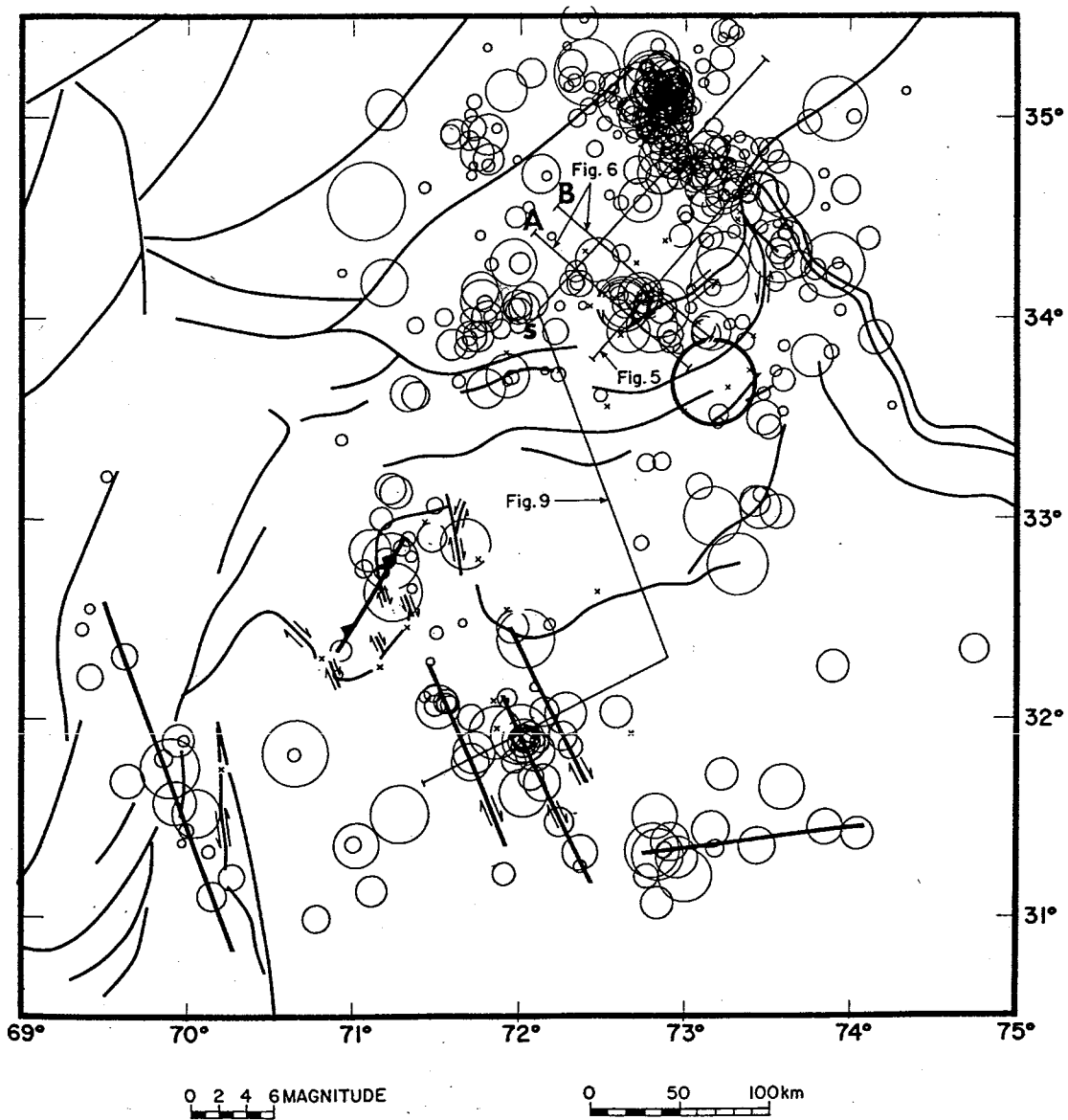

The Chashma data is for May-November 1976 and the Tarbela data for February-August 1976. The size of the circles represents earthquake magnitudes.

Source : L. Seeber and J. Armbruster, Seismicity of Hazara arc: decollement vs. basement faulting, in Geodynamics of Pakistan, A. Farah and K. A. DeJong, editors, Geological Survey of Pakistan, Quetta, 1979, p. 133

Map 8 : Areas affected by floods in Pakistan in 1992

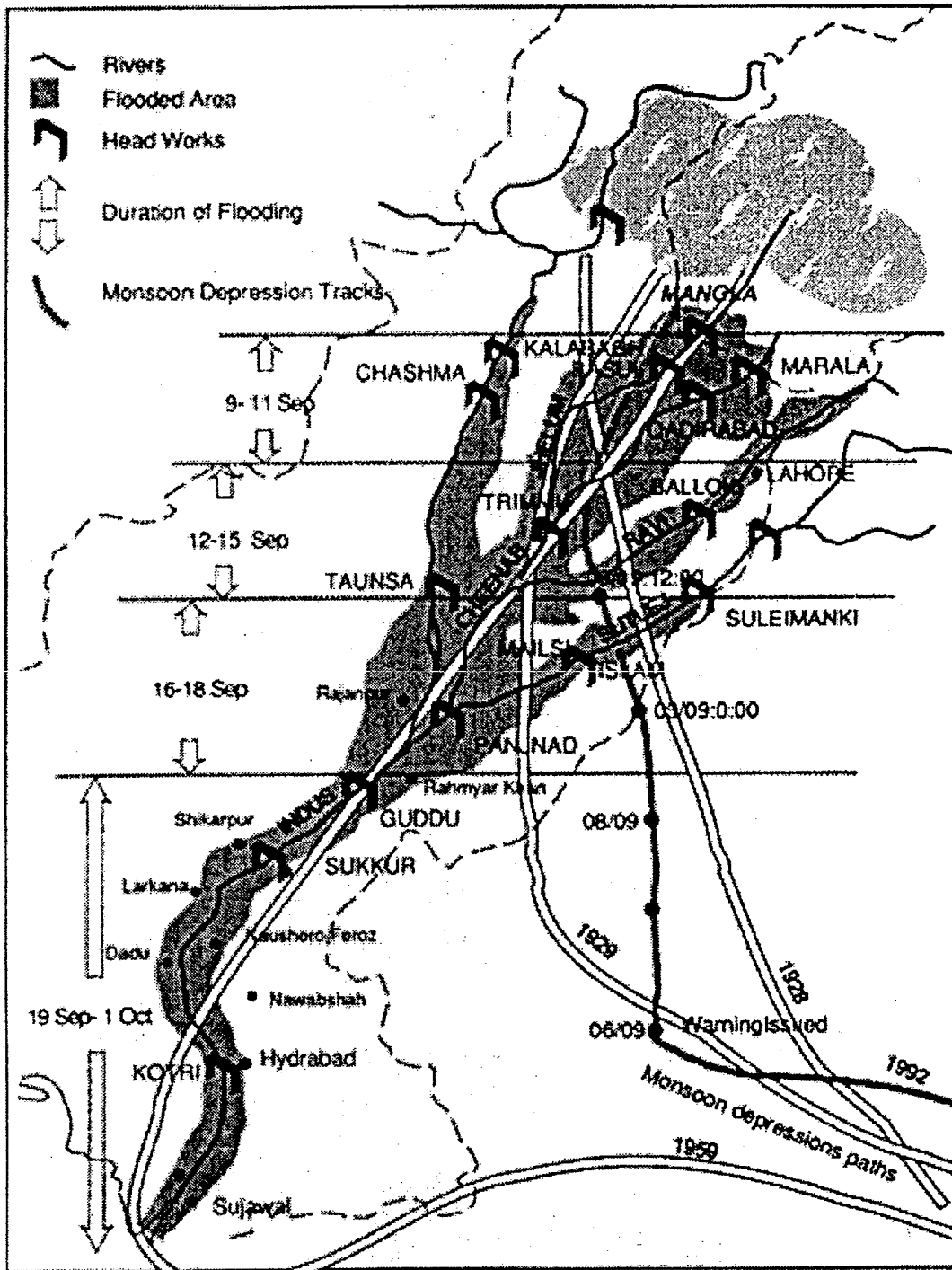

Source: S. Herath and B. Bhatti, Pakistan floods September '92, International Center for Disaster-Mitigation Engineering Newsletter, Vol. 1, no. 2, 1992.

<http://incede.iis.u-tokyo.ac.jp/default.html>

Appendix 1 : A comparison of Chashma and Qinshan-1

The column for Qinshan contains only the numbers that differ from those for Chashma. The blank columns should be read as having the same values as for Chashma.

| | CHASHMA | QINSHAN 1 |
|---|------------------|-----------|
| CORE | | |
| Height (m) | 2.9 | |
| Diameter (m) | 2.486 | |
| Fuel inventory (t) | 35.917 | 40.746 |
| # assemblies | 121 | |
| rod pitch (cm) | 1.33 | |
| assembly pitch (cm) | 20.03 | |
| peak power rating (kW/l) | 191.43 | 206.9 |
| average power rating (kW/l) | 70.9 | 68.6 /l |
| expected burnup (MWd/tHM) | 30000 | 24000 |
| peak assembly discharge burn up (MWd/tHM) | 39500 | 37000 |
| # cycles to full burnup | 3 | --- |
| REACTOR VESSEL | | |
| vessel material | SA 508 111 | |
| shape | cylinder | |
| wall thickness (mm) | 175 | |
| clad thickness (mm) | 4 | 6 |
| height (m) | 10.7 | |
| inner diameter (m) | 3.374 | 3.732 |
| max overall RPV diameter (m) | 5.596 | |
| CONTAINMENT STRUCTURE | | |
| containment design pressure (kg/sq cm) | 2.65 | |
| containment type | steel concrete | --- |
| inside diameter (m) | 36 | |
| thickness (m) | 1 | |
| total height (m) | 57 | |
| containment lining (mm) | 6, steel | |
| foundation raft under the reactor PV (m) | 5.65 | |
| FUEL | | |
| fuel material | UO ₂ | |
| enrichment of initial core | 2.4 /2.67 /3.0 % | |
| enrichment of reloads | 3.4 % | 3.0 % |
| fuel form | pellet | |
| # rods per assembly | 204 | |
| geometry | 15×15 | |
| pin height (mm) | 3210 | 3200 |
| pin outside diameter (mm) | 10 | |
| pellet height (mm) | 10 | |
| pellet outside diameter (mm) | 8.43 | |
| average linear fuel rating (kW/m) | 13.59 | 13.50 |
| peak linear fuel rating (kW/m) | 36.69 | 40.7 |
| maximum clad temperature (C) | 345.7 | 404 |
| maximum centre line temperature (C) | 1806 | 1881 |
| clad material | zircaloy 4 | |
| clad thickness (mm) | 0.7 | |
| COOLANT | | |
| coolant material | H ₂ O | |

| | | |
|--|---------------------------------|--------|
| weight in primary circuit (t) | 142 | 165 |
| inlet temperature (C) | 288.5 | 288.8 |
| outlet temperature (C) | 315.5 | 315.2 |
| pressure (kg/sq. cm) | 155 | |
| # primary pumps | 2 | |
| total mass flow (t/hr) | 24000 | |
| # loops | 2 | |
| steam generator tube material | incoloy 800 | |
| Secondary cooling water from canal (m ³ /s) | 25 | |
| MODERATOR | | |
| moderator material | H ₂ O | --- |
| form | liquid | --- |
| weight (t) | 57 | --- |
| average temperature at full load (C) | 302 | --- |
| CONTROL RODS | | |
| # coarse rods | 420 | 37 |
| # fine rods | --- | 21 |
| # safety rods | 320 | 16 |
| rod material | Ag-In-Cd | |
| other systems | boron dilution | CS |
| burnable poison | borated glass | GG-17 |
| control rod drives | --- | 37 |
| axial or radial shuffling | radial | ---- |
| shutdown period (days) | 30 | 60 |
| shutdown frequency (months) | 12 | |
| fuel loading (t/y) | 11.87 | 13.469 |
| fraction of core reloaded each cycle | 33.3 % | |
| SPENT FUEL | | |
| amount of spent fuel in fuel pool (1994) (tHM) | --- | 30 |
| original capacity of pool (tHM) | 220 | 1026 |
| TURBINES | | |
| # turbine | 1 | |
| speed (rev /m) | 3000 | |
| rating (MWe) | 325 | 310 |
| stop valve pressure (kg/sq. cm) | 53.4 | 54.5 |
| stop valve temperature (C) | 268.3 | 268.1 |
| POWER GENERATION | | |
| gross electric power output (MWe) | 325 | --- |
| estimated net electric power output (MWe) | 300 | --- |
| thermal power (MWth) | 998.6 | --- |
| Plant life-span | 40 years (70% av. plant factor) | --- |

Source: Nuclear Engineering International, World Nuclear Industry Handbook, 1994 and 1997

Appendix 2: Earthquakes with epicenters within 100 km of the Chashma site

| Year | Depth (km) | Magnitude | Distance (km) |
|------|------------|-----------|---------------|
| 1973 | 26 | 4.60 | 94 |
| 1976 | 33 | -- | 29 |
| 1978 | 33 | -- | 38 |
| 1981 | 57 | 4.60 | 32 |
| 1982 | 33 | 5.20 | 94 |
| 1983 | 33 | 3.50 | 87 |
| 1984 | 33 | -- | 99 |
| 1985 | 33 | -- | 97 |
| 1985 | 93 | 4.70 | 95 |
| 1987 | 33 | -- | 67 |
| 1987 | 33 | 3.70 | 56 |
| 1989 | 33 | 4.70 | 37 |
| 1990 | 33 | 4.40 | 56 |
| 1990 | 33 | 4.10 | 75 |
| 1991 | 33 | 4.40 | 93 |
| 1991 | 33 | 4.30 | 78 |
| 1992 | 33 | 3.80 | 97 |
| 1992 | 33 | 4.60 | 95 |
| 1992 | 33 | 4.90 | 91 |
| 1992 | 33 | 4.40 | 96 |
| 1992 | 33 | 3.90 | 66 |
| 1993 | 72 | 4.60 | 35 |
| 1993 | 33 | 4.70 | 99 |
| 1996 | 33 | 4.70 | 84 |

Source: United States Geological Survey National Earthquake Information Centre, Earthquake Database, September 1999.

The Chashma site is assumed to be at 32.433N, 71.433E, and the magnitude is the body-wave magnitude

Appendix 3: Estimated radioactive inventory at time of accident and the fraction and total amounts of radionuclides assumed released from the Chashma reactor

| Isotope | Half life (days) | Chashma inventory at equilibrium (Megacuries) | Fraction of core inventory assumed released | Chashma Release to atmosphere (Megacuries) |
|---------------------|------------------|---|---|--|
| NOBLE GASES | | | 0.9 | |
| Kr-85 | 10.76 (y) | 0.18 | | 0.162 |
| Kr-85* | .18 | 7.88 | | 7.1 |
| Kr-87 | .053 | 15.76 | | 14.2 |
| Kr-88 | .116 | 23.03 | | 20.7 |
| Xe-133 | 5.3 | 51.51 | | 46.36 |
| Xe-135 | .38 | 7.88 | | 7.1 |
| IODINES | | | 0.7 | |
| I-131 | 8.05 | 25.76 | | 18.03 |
| I-132 | .1 | 36.36 | | 25.45 |
| I-133 | .875 | 51.51 | | 36.06 |
| I-134 | .036 | 60.61 | | 42.43 |
| I-135 | .28 | 45.45 | | 31.8 |
| TELLURIUMS | | | 0.5 | |
| Te-129 | .048 | 8.48 | | 2.54 |
| Te-129* | 34.1 | 3.03 | | 0.91 |
| Te-131 | 1.25 | 4.54 | | 1.36 |
| Te-132 | 3.25 | 36.36 | | 10.9 |
| CESIUMS | | | 0.3 | |
| Cs-134 | 2 years | 0.51 | | 0.26 |
| Cs-136 | 12.9 | 1.82 | | 0.91 |
| Cs-137 | 30 years | 1.76 | | 0.88 |
| VOLATILE OXIDES | | | 0.02 | |
| Mo-99 | 2.8 | 48.48 | | 0.97 |
| Tc-99 | 0.25 | 42.42 | | 0.85 |
| Ru-103 | 40 | 30.3 | | 0.61 |
| Ru-105 | 0.18 | 17.57 | | 0.35 |
| Ru-106 | 1 year | 5.76 | | 0.11 |
| Rh-105 | 1.5 | 17.57 | | 0.35 |
| ALKALINE EARTHS | | | 0.06 | |
| Ba-140 | 12.8 | 48.48 | | 2.91 |
| Sr-89 | 50.6 | 33.33 | | 2.0 |
| Sr-90 | 27.7 years | 1.56 | | 0.09 |
| Sr-91 | 0.4 | 39.39 | | 2.36 |
| NON-VOLATILE OXIDES | | | 0.004 | |
| Y-90 | 2.7 | 1.58 | | 0.006 |
| Y-91 | 59 | 42.42 | | 0.17 |
| Zr-95 | 65.5 | 48.48 | | 0.19 |
| Zr-97 | 0.7 | 48.48 | | 0.19 |
| Nb-95 | 3.5 | 48.48 | | 0.19 |
| La-140 | 1.66 | 48.48 | | 0.19 |
| Ce-141 | 32.8 | 48.48 | | 0.19 |
| Ce-143 | 1.37 | 45.45 | | 0.18 |

| | | | | |
|--------|-------------|-------|--|----------|
| Ce-144 | 285 | 33.33 | | 0.13 |
| Pr-143 | 13.6 | 45.45 | | 0.18 |
| Nd-147 | 11 | 18.18 | | 0.07 |
| Pm-147 | 2.65 years | 5.15 | | 0.02 |
| Pm-149 | 2.2 | 12.12 | | 0.05 |
| Pu-238 | 86.4 years | 0.03 | | 0.00012 |
| Pu-239 | 24390 years | 0.003 | | 0.000012 |

The total release from Chashma core into the atmosphere is estimated to be 973.4 Megacuries.

Appendix 4: The time-integrated radioactivity $\chi(r)$ for each isotope at distances of 10, 100 and 1000 km from the reactor site

| Isotope | Half life (days) | Chashma Release to atmosphere (Megacuries) | $\chi(10 \text{ km})$ curies-sec/m ³ | $\chi(100\text{km})$ curies-sec/m ³ | $\chi(1000 \text{ km})$ curies-sec/m ³ |
|---------|------------------|--|---|--|---|
| Kr-85 | 10.76 (y) | 0.162 | 9818 | 982 | 98 |
| Kr-85* | .18 | 7.1 | 399497 | 20472 | 3 |
| Kr-87 | .053 | 14.2 | 668713 | 6905 | 0.0 |
| Kr-88 | .116 | 20.7 | 1117962 | 39618 | 0.1 |
| Xe-133 | 5.3 | 46.36 | 2802618 | 273970 | 21832 |
| Xe-135 | .38 | 7.092 | 414840 | 30224 | 127 |
| I-131 | 8.05 | 18.03 | 1082681 | 99632 | 4338 |
| I-132 | .1 | 25.45 | 1339198 | 37550 | 0.01 |
| I-133 | .875 | 36.06 | 2136069 | 173891 | 2223 |
| I-134 | .036 | 42.428 | 1760338 | 5811 | 0.0 |
| I-135 | .28 | 31.8 | 1823535 | 110829 | 76 |
| Te-129 | .048 | 2.54 | 116160 | 921 | 0.0 |
| Te-129* | 34.1 | .91 | 54359 | 5271 | 387 |
| Te-131 | 1.25 | 1.36 | 81300 | 7185 | 209 |
| Te-132 | 3.25 | 10.9 | 655903 | 61506 | 3233 |
| Cs-134 | 2 years | .26 | 15710 | 1528 | 116 |
| Cs-136 | 12.9 | .91 | 54928 | 5295 | 367 |
| Cs-137 | 30 years | .88 | 53172 | 5174 | 394 |
| Mo-99 | 2.8 | 0.97 | 58331 | 5437 | 269 |
| Tc-99 | 0.25 | 0.85 | 48685 | 2927 | 2 |
| Ru-103 | 40 | 0.61 | 36846 | 3575 | 264 |
| Ru-105 | 0.18 | 0.35 | 19634 | 979 | 0.09 |
| Ru-106 | 1 year | 0.11 | 6646 | 647 | 49 |
| Rh-105 | 1.5 | 0.35 | 20960 | 1882 | 64 |
| Ba-140 | 12.8 | 2.91 | 175646 | 16932 | 1173 |
| Sr-89 | 50.6 | 2.0 | 120813 | 11728 | 872 |
| Sr-90 | 27.7 years | .09 | 5438 | 529 | 40 |
| Sr-91 | 0.4 | 2.36 | 102080 | 490 | 0.0 |
| Y-90 | 2.7 | .006 | 361 | 34 | 2 |
| Y-91 | 59 | 0.17 | 10270 | 997 | 74 |
| Zr-95 | 65.5 | 0.19 | 11478 | 1115 | 83 |
| Zr-97 | 0.7 | 0.19 | 11263 | 923 | 13 |
| Nb-95 | 3.5 | 0.19 | 11437 | 1075 | 58 |
| La-140 | 1.66 | 0.19 | 11388 | 1031 | 38 |
| Ce-141 | 32.8 | 0.19 | 11476 | 1113 | 82 |
| Ce-143 | 1.37 | 0.18 | 10770 | 960 | 30 |
| Ce-144 | 285 | 0.13 | 7855 | 764 | 58 |
| Pr-143 | 13.6 | 0.18 | 10865 | 1048 | 73 |
| Nd-147 | 11 | 0.07 | 4224 | 407 | 28 |
| Pm-147 | 2.65 years | 0.02 | 1208 | 118 | 9 |
| Pm-149 | 2.2 | 0.05 | 3003 | 277 | 12 |
| Pu-238 | 86.4 years | 0.00012 | 6 | 0.6 | 0.04 |
| Pu-239 | 24390 years | 0.000012 | 0.7 | 0.07 | 0.005 |

Appendix 5: Population in selected cities and districts of the Punjab and North West Frontier Province in Pakistan (millions) and population density in the districts for 1998

| District | Population in City | Total in District | District Area (km ²) | District population density per (km ²) |
|----------------|--------------------|-------------------|----------------------------------|--|
| Lahore | 5.063 | 6.213 | 1772 | 3506 |
| Faisalabad | 1.977 | 5.341 | 9108 | 586 |
| Rawalpindi | 1.406 | 3.352 | 5286 | 634 |
| Multan | 1.182 | 1.970 | 10847 | 182 |
| Gujranwala | 1.125 | 3.374 | 5988 | 563 |
| Peshawar | 0.984 | 2.039 | 4001 | 509 |
| Sargodha | 0.455 | 2.653 | 12367 | 214 |
| Sialkot | 0.418 | 2.689 | 5353 | 502 |
| Bahawalpur | 0.403 | 2.411 | 24830 | 97 |
| Jhang | 0.292 | 2.804 | 8809 | 318 |
| Sheikhupura | 0.272 | 3.230 | 5960 | 542 |
| Gujrat | 0.250 | 1.842 | 5865 | 314 |
| Mardan | 0.244 | 1.450 | 3137 | 462 |
| Kasur | 0.241 | 2.347 | 3995 | 587 |
| Rahim Yar Khan | 0.228 | 1.841 | 11880 | 163 |
| Sahiwal | 0.207 | 1.821 | 10303 | 177 |

Source: Provisional Results of Fifth Population and Housing Census Held in March 1998, Population Census Organisation, Statistics Division, Government of Pakistan, July 1998.

The area of the districts in Punjab and the North-West Frontier Province is taken from the Handbook of Population Census Data, Population Census Organization, Islamabad, 1987.

Appendix 6: The dose conversion factors used in calculating dose to population

| Isotope | Half-life | Radioactivity in the plume (10 ⁹ curies) | Deposition velocity (m/s) | Dose conversion coefficients | | | |
|--------------------|-----------|---|---------------------------|------------------------------|-------------------------|-------------------------------------|--------------------------------------|
| | | | | Inhalation | | External irradiation | |
| | | | | whole body (rem/m Ci) | Lung (1 day) (rem/m Ci) | Ground (rem/h)/(Ci/m ²) | Cloud (rem/h)/(Ci-s/m ³) |
| ⁸⁵ Kr | 10.76 y | 0.162 | 0 | 0 | 0 | 10.7 | 0.05 |
| ⁸⁵ Kr* | 0.18 d | 7.1 | 0 | 0 | 0 | 20.1 | 0.11 |
| ⁸⁷ Kr | 0.053 d | 14.2 | 0 | 0 | 0 | 189.3 | 0.66 |
| ⁸⁸ Kr | 0.116 d | 20.7 | 0 | 0 | 0 | 88.1 | 0.88 |
| ¹³³ Xe | 5.3 d | 46.36 | 0 | 0 | 0 | 1.53 | 0.024 |
| ¹³⁵ Xe | 0.38 d | 7.09 | 0 | 0 | 0 | 31 | 0.16 |
| ¹³¹ I | 8.05 d | 18.03 | .005 | 27.4 | 8 | 13.6 | 0.18 |
| ¹³² I | 0.1 d | 25.45 | .005 | .38 | 4.6 | 129.7 | 1.00 |
| ¹³³ I | 0.875 d | 36.06 | .005 | 5.6 | 6.8 | 68.5 | 0.32 |
| ¹³⁴ I | 0.036 d | 42.43 | .005 | .19 | 2.63 | 134 | 1.17 |
| ¹³⁵ I | 0.28 d | 31.8 | .005 | 1.23 | 6.81 | 84 | 0.07 |
| ¹²⁹ Te* | 34.1 d | .9 | .002 | 5.51 | 8.2 | 30.69 | 0.06 |
| ¹²⁹ Te | 0.048 d | 1.36 | .002 | 3.37 | 16.2 | 47.5 | 0.33 |
| ¹³¹ Te | 1.25 d | 10.9 | .002 | 7.21 | 29.2 | 7 | 0.09 |
| ¹³⁴ Cs | 2 y | .26 | .002 | 41 | 67 | 49 | 0.63 |
| ¹³⁶ Cs | 12.9 d | .91 | .002 | 6.9 | 36.1 | 61.6 | 0.03 |
| ¹³⁷ Cs | 30 y | .88 | .002 | 30 | 43.3 | 3.66 | 0.03 |
| ⁹⁹ Mo | 2.8 d | .97 | .002 | 1.1 | 6.32 | 52 | 0.14 |
| ⁹⁹ Tc* | 0.25 d | .85 | .002 | 1.17 | 3.0 | 3.52 | 0.05 |
| ¹⁰³ Ru | 40 d | .61 | .002 | 2.7 | 10.5 | 14.4 | 0.19 |
| ¹⁰⁶ Ru | 1 y | .11 | .002 | 55.1 | 58.5 | 0.0 | 0.44 |
| ¹⁴⁰ Ba | 12.8 d | 2.91 | .002 | 4.07 | 15 | 28.3 | 0.12 |
| ⁸⁹ Sr | 50.6 d | 2.0 | .002 | 4.37 | 4.8 | 88.6 | 0.14 |
| ⁹⁰ Sr | 27.7 y | .09 | .002 | 91 | 8.55 | 1.87 | 0.03 |
| ⁹⁵ Zr | 65.5 d | .19 | .002 | 11.9 | 20 | 21.5 | 0.30 |
| ⁹⁵ Nb | 3.5 d | .19 | .002 | 2.92 | 12.54 | 22 | 0.30 |
| ¹⁴¹ Ce | 32.8 d | .19 | .002 | 3.88 | 6.33 | 2.74 | 0.05 |
| ¹⁴³ Ce | 1.37 d | .13 | .002 | 168 | 48 | 0.62 | 0.01 |
| ²³⁸ Pu | 86.4 y | .0001 | .002 | 429940 | 46250 | 0.14 | 0.0002 |
| ²³⁹ Pu | 24390 y | .000012 | .002 | 469900 | 51800 | 0.054 | 0.0001 |

Source: The inhalation coefficients are from the Annals of the International Commission on Radiological Protection: Age-dependent Doses to Members of the Public from Intake of Radionuclides: Part 4; Inhalation dose coefficients, Vol. 25, Nos. 3-4, 1995.

For external radiation, the coefficients are from US Environmental Protection Agency, External Exposure to Radionuclides in Air, Water and Soil, Federal Guidance Report, No. 12, US EPA, Washington DC, 1993

The skin coefficients have been added the EPA effective dose to get the whole body dose, and extrathoracic airways have been added to the lungs. Only those isotopes are included which are common to both the APS study and the International Commission on Radiological Protection reports.

Appendix 7: Radiation dose from Chashma

| Isotope | Inhalation dose (10 ⁶ person-rem) | | External dose (10 ⁶ person-rem) | | |
|--------------------|---|----------------|---|----------------|----------------|
| | Whole body | Lungs (30 day) | Cloud shine | Ground (1 day) | Ground (total) |
| ⁸⁵ Kr | 0.00 | 0.00 | 0.00 | 0.00 | 0.00 |
| ⁸⁵ Kr* | 0.00 | 0.00 | 0.00 | 0.00 | 0.00 |
| ⁸⁷ Kr | 0.00 | 0.00 | 0.01 | 0.00 | 0.00 |
| ⁸⁸ Kr | 0.00 | 0.00 | 0.04 | 0.00 | 0.00 |
| ¹³³ Xe | 0.00 | 0.00 | 0.01 | 0.00 | 0.00 |
| ¹³⁵ Xe | 0.00 | 0.00 | 0.01 | 0.00 | 0.00 |
| ¹³¹ I | 3.24 | 0.94 | 0.02 | 0.18 | 1.57 |
| ¹³² I | 0.02 | 0.20 | 0.04 | 0.07 | 0.07 |
| ¹³³ I | 1.10 | 1.33 | 0.06 | 0.97 | 1.42 |
| ¹³⁴ I | 0.01 | 0.07 | 0.03 | 0.02 | 0.02 |
| ¹³⁵ I | 0.14 | 0.79 | 0.01 | 0.32 | 0.33 |
| ¹²⁹ Te | 0.04 | 0.05 | 0.00 | 0.01 | 0.33 |
| ¹²⁹ Te* | 0.03 | 0.14 | 0.00 | 0.01 | 0.02 |
| ¹³¹ Te | 0.53 | 2.15 | 0.01 | 0.02 | 0.08 |
| ¹³⁴ Cs | 0.08 | 0.12 | 0.00 | 0.00 | 3.23 |
| ¹³⁶ Cs | 0.04 | 0.23 | 0.01 | 0.02 | 0.25 |
| ¹³⁷ Cs | 0.19 | 0.27 | 0.00 | 0.00 | 5.26 |
| ⁹⁹ Mo | 0.01 | 0.04 | 0.00 | 0.01 | 0.05 |
| ⁹⁹ Tc* | 0.00 | 0.01 | 0.00 | 0.00 | 0.00 |
| ¹⁰³ Ru | 0.01 | 0.05 | 0.00 | 0.00 | 0.12 |
| ¹⁰⁶ Ru | 0.04 | 0.05 | 0.00 | 0.00 | 0.00 |
| ¹⁴⁰ Ba | 0.08 | 0.31 | 0.00 | 0.03 | 0.36 |
| ⁸⁹ Sr | 0.06 | 0.07 | 0.00 | 0.06 | 3.10 |
| ⁹⁰ Sr | 0.06 | 0.01 | 0.00 | 0.00 | 0.59 |
| ⁹⁵ Zr | 0.02 | 0.03 | 0.00 | 0.00 | 0.09 |
| ⁹⁵ Nb | 0.00 | 0.02 | 0.00 | 0.00 | 0.00 |
| ¹⁴¹ Ce | 0.01 | 0.01 | 0.00 | 0.00 | 0.01 |
| ¹⁴³ Ce | 0.16 | 0.04 | 0.00 | 0.00 | 0.01 |
| ²³⁸ Pu | 0.31 | 0.03 | 0.00 | 0.00 | 0.00 |
| ²³⁹ Pu | 0.04 | 0.00 | 0.00 | 0.00 | 0.00 |
| Total | 6.2 | 6.97 | 0.26 | 1.74 | 16.92 |

The inhalation coefficients are from the Annals of the International Commission on Radiological Protection: Age-dependent Doses to Members of the Public from Intake of Radionuclides: Part 4; Inhalation dose coefficients, Vol. 25, Nos. 3-4, 1995.

The external cloud and ground dose coefficients are from US Environmental Protection Agency: External Exposure to Radionuclides In Air, Water and Soil, US EPA, Washington DC, 1993.

Appendix 8 : Thyroid doses

| Isotope | Coefficients for inhalation dose to thyroid (in rem/millicurie) ²⁶⁵ | | Thyroid dose (in million person-rem) | |
|-------------------|--|-----------------------------------|--------------------------------------|-----------------------------------|
| | children up to the age of 15 years | persons above the age of 15 years | children up to the age of 15 years | persons above the age of 15 years |
| ¹³¹ I | 3049 | 555 | 87.30 | 50.06 |
| ¹³² I | 4 | 0.52 | 0.04 | 0.02 |
| ¹³³ I | 746 | 104 | 35.40 | 15.55 |
| ¹³⁴ I | 6.6 | 0.96 | 0.05 | 0.02 |
| ¹³⁵ I | 151 | 21.1 | 4.26 | 1.87 |
| ¹²⁹ Te | 115 | 15 | 0.18 | 0.07 |
| ¹³¹ Te | 279 | 48 | 0.56 | 0.31 |
| ¹³² Te | 658 | 93 | 11.74 | 5.23 |
| ¹³⁴ Cs | 24 | 23 | 0.01 | 0.03 |
| ¹³⁶ Cs | 11 | 3.7 | 0.02 | 0.02 |
| ¹³⁷ Cs | 17 | 16 | 0.03 | 0.08 |
| ⁸⁹ Sr | 2.95 | 0.67 | 0.010 | 0.007 |
| ⁹⁰ Sr | 11 | 2.2 | 0.002 | 0.001 |

²⁶⁵ International Commission on Radiological Protection, *Age-dependent Doses to Members of the Public from Intake of Radionuclides: Part 4; Inhalation dose coefficients*, Annals of the ICRP, Vol. 25, Nos. 3-4, 1995.

Appendix 9: Radionuclide deposition on the Chashma barrage water body

| Isotope | Radionuclide deposition on the Chashma barrage water body (megacuries) |
|--------------------|--|
| ¹³¹ I | 0.40 |
| ¹³² I | 0.41 |
| ¹³³ I | 0.77 |
| ¹³⁴ I | 0.39 |
| ¹³⁵ I | 0.63 |
| ¹²⁹ Te | 0.008 |
| ¹²⁹ Te* | 0.001 |
| ¹³¹ Te | 0.01 |
| ¹³⁴ Cs | 0.002 |
| ¹³⁶ Cs | 0.008 |
| ¹³⁷ Cs | 0.008 |
| ⁹⁹ Mo | 0.009 |
| ⁹⁹ Tc* | 0.007 |
| ¹⁰³ Ru | 0.006 |
| ¹⁰⁶ Ru | 0.001 |
| ¹⁴⁰ Ba | 0.002 |
| ⁸⁹ Sr | 0.002 |
| ⁹⁰ Sr | 0.0008 |
| ⁹⁵ Zr | 0.002 |
| ⁹⁵ Nb | 0.002 |
| ¹⁴¹ Ce | 0.002 |
| ¹⁴³ Ce | 0.001 |
| ²³⁸ Pu | 9.02E-07 |
| ²³⁹ Pu | 1.08E-07 |